

**RADIO RECEIVER AN/GRR-2**  
**(HALLICRAFTERS MODEL SX-28-A)**



WAR DEPARTMENT

22 NOVEMBER 1944

---

**RESTRICTED.** *DISSEMINATION OF RESTRICTED MATTER.*  
The information contained in restricted documents and the essential characteristics of restricted material may be given to any person known to be in the service of the United States and to persons of undoubted loyalty and discretion who are cooperating in Government work, but will not be communicated to the public or to the press except by authorized military public relations agencies. (See also par. 23*b*, AR 380-5, 15 Mar 1944.)

---



*WAR DEPARTMENT TECHNICAL MANUAL*  
*TM 11-874*

---

**RADIO RECEIVER AN/GRR-2**  
**(HALLICRAFTERS MODEL SX-28-A)**



*WAR DEPARTMENT*

*22 NOVEMBER 1944*

---

**RESTRICTED.** *DISSEMINATION OF RESTRICTED MATTER.*  
The information contained in restricted documents and the essential characteristics of restricted material may be given to any person known to be in the service of the United States and to persons of undoubted loyalty and discretion who are cooperating in Government work, but will not be communicated to the public or to the press except by authorized military public relations agencies. (See also par. 23*b*, AR 380-5, 15 Mar 1944.)

---

WAR DEPARTMENT,  
WASHINGTON 25, D. C., 22 November 1944.

TM 11-874, Radio Receiver AN/GRR-2, (Hallicrafters Model SX-28-A) is published for the information and guidance of all concerned.

[A. G. 300.7 (20 Apr. 44).]

BY ORDER OF THE SECRETARY OF WAR:

G. C. MARSHALL,  
*Chief of Staff.*

OFFICIAL:

J. A. ULIO,  
*Major General,*  
*The Adjutant General.*

DISTRIBUTION:

Armies (Sig) (5); Sv C (Sig) (5); Dept (Sig) (5); Def (Sig) (2); Base C (5); T of Opn (5); D (2);\* P, C & S (2); PE's (Sig) (2); Tech Svs (2); Arm & Sv Boards (2); Sp Sv Sch (10); ROTC (5); Sig C Dep (2); Gen O/S SOS Dep (Sig Sec) (2); Sig C Labs (2); Sig C Rep Shs (2).

\*IBn 11(2); IC 11(5);

IBn 11: T/O & E 11-15; 11-25; 11-95.

IC 11: T/O & E 11-7; 11-47; 11-57; 11-107; 11-127; 11-237; 11-287; 11-587; 11-592; 11-597.

For explanation of symbols, see FM21-6.

# TABLE OF CONTENTS

---

SECTION	I. Description.	<i>Paragraph</i>	<i>Page</i>
	General .....	1	1
	Weights and dimensions.....	2	1
	Frequency coverage .....	3	1
	Tubes and circuits.....	4	1
	Power requirements .....	5	2
	Power output .....	6	2
	Normal performance characteristics .....	7	2
	II. Installation and operation.		
	Unpacking .....	8	3
	Preparation for use.....	9	3
	Operation .....	10	5
	III. Functioning of parts.		
	General .....	11	10
	R-f amplifier .....	12	10
	Mixer .....	13	15
	H-f oscillator .....	14	16
	I-f amplifier .....	15	17
	Detector .....	16	20
	Noise limiter .....	17	21
	A-v-c amplifier .....	18	22
	Audio amplifier .....	19	25
	Beat-frequency oscillator .....	20	29
	Power supply .....	21	29
	IV. Maintenance.		
	Inspection .....	22	30
	Lubrication .....	23	31
	Replacement .....	24	31
	Field adjustments .....	25	31
	Trouble location chart.....	26	31
	Voltage readings .....	27	33
	Resistance measurements .....	28	33
	Alignment procedure .....	29	41
	Performance specifications.....	30	46
	Moistureproofing and fungiproofing .....	31	50
	V. Supplementary data.		
	Maintenance parts list.....	32	54
	List of manufacturers.....	33	61

# LIST OF ILLUSTRATIONS

---

<i>Fig. No.</i>	<i>Title</i>	<i>Page</i>
1.	Radio Receiver AN/GRR-2 .....	VI
2.	Radio Receiver AN/GRR-2, rear chassis apron.....	4
3.	Radio Receiver AN/GRR-2, operating control panel..	6
4.	I-f selectivity curves without crystal filter.....	7
5.	Crystal selectivity curves .....	9
6.	Effect of correct adjustment of CRYSTAL PHASING control .....	9
7.	Radio Receiver AN/GRR-2, block diagram.....	11
8.	Radio Receiver AN/GRR-2, top view of chassis.....	12
9.	R-f amplifier, schematic .....	14
10.	Mixer stage, schematic .....	15
11.	High-frequency oscillator, schematic .....	16
12.	First i-f amplifier, detector, and A.N.L., schematic...	18
13.	Crystal filter and second i-f amplifier, schematic....	19
14.	Automatic-volume-control amplifier, schematic.....	22
15.	A-v-c curve taken at 3 megacycles.....	23
16.	Audio amplifier, schematic.....	24
17.	Effect of TONE control on audio fidelity at BROAD I.F. and SHARP I.F. positions of SELECTIVITY control, BASS switch at IN position.....	26
18.	Audio frequency response with BASS switch IN and OUT, SELECTIVITY control at XTAL SHARP position .....	26
19.	Beat-frequency oscillator, schematic.....	27
20.	Power supply, schematic.....	28
21.	Voltage readings .....	34
22.	I-f aligning adjustments .....	42
23.	R-f and oscillator adjustments .....	45
24.	Radio Receiver AN/GRR-2, bottom view.....	48
25.	Color code chart .....	49
26.	Dimensional drawing .....	62
27.	Radio Receiver AN/GRR-2; schematic.....	63

# DESTRUCTION NOTICE

**WHY** —To prevent the enemy from using or salvaging this equipment for his benefit.

**WHEN**—When ordered by your commander.

**HOW** —1. Smash—Use sledges, axes, handaxes, pickaxes, hammers, crowbars, heavy tools.  
2. Cut —Use axes, handaxes, machetes.  
3. Burn —Use gasoline, kerosene, oil, flame throwers, incendiary grenades.  
4. Explosives—Use firearms, grenades, TNT.  
5. Disposal —Bury in slit trenches, fox holes, other holes. Throw in streams. Scatter.

## USE ANYTHING IMMEDIATELY AVAILABLE FOR DESTRUCTION OF THIS EQUIPMENT.

**WHAT**—1. Smash—Every electrical or mechanical part, whether rotating, moving, or fixed.  
2. Cut —All wiring, leads, cables, and canvas bags.  
3. Burn —All technical manuals, diagrams, capacitors, fuel supplies, and carrying cases.  
4. Bend —All panels, switchboards, dials, and cabinets.  
5. Bury or scatter—All remaining parts.

# DESTROY EVERYTHING

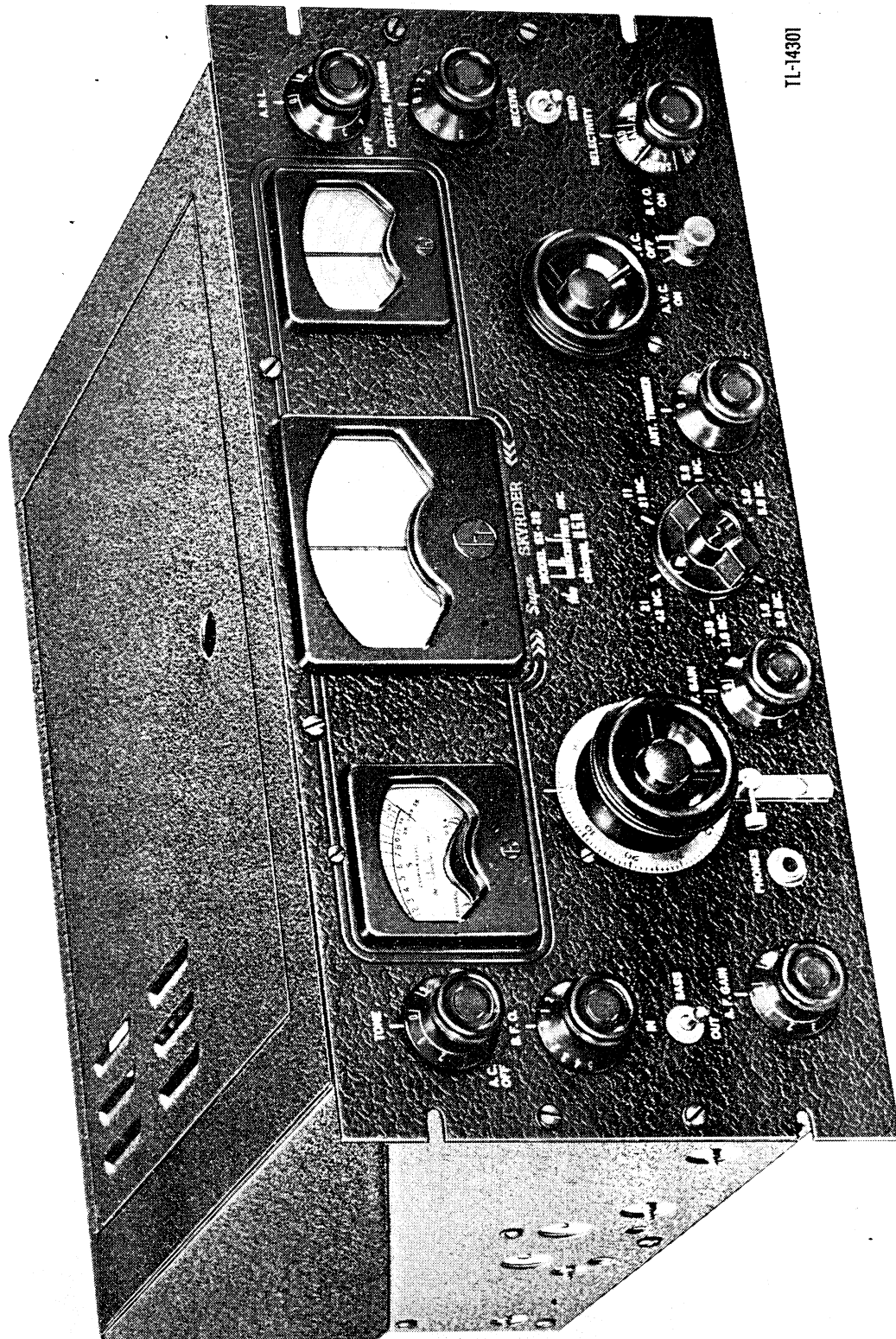

Figure 1. Radio Receiver AN/GRR-2.

# RESTRICTED

## SECTION I

### DESCRIPTION

#### 1. GENERAL.

Radio Receiver AN/GRR-2 (Hallicrafters Model SX-28-A) (fig. 1) is a 15-tube superheterodyne receiver covering the frequency range of 550 kilocycles (kc) to 42 megacycles (mc) in six bands. It is designed to receive amplitude-modulated (a-m) or keyed continuous-wave (c-w) signals. The receiver may be operated with the internal power supply from an a-c source, or from an external d-c source.

#### 2. WEIGHTS AND DIMENSIONS.

The complete receiver weighs 78 pounds and is 16½ inches deep, 20¾ inches wide, and 10¾ inches high. Packed for shipment the set weighs 135 pounds and is 21½ inches deep, 27 inches wide, and 15½ inches high.

#### 3. FREQUENCY COVERAGE.

a. The six bands cover the following frequencies:

550 kc to 1.6 mc	1.6 mc to 3.0 mc	3.0 mc to 5.8 mc
5.8 mc to 11 mc	11 mc to 21 mc	21 mc to 42 mc

b. All six bands are calibrated on the main tuning dial for direct reading, providing the band spread dial is set at 100 on the 0 to 100 scale.

c. The band spread knob may be used for vernier tuning on any part of the four highest frequency bands, but the scale is only calibrated for a portion of these four bands.

3.0- to 5.8-mc band	3,500 to 4,000 kc
5.8- to 11-mc band	7,000 to 7,300 kc
11- to 21-mc band	14,000 to 14,450 kc
21- to 42-mc band	28,000 to 30,000 kc

#### 4. TUBES AND CIRCUITS.

The following tubes and circuits are used in Radio Receiver AN/GRR-2:

<i>Circuit</i>	<i>Tube</i>	<i>Circuit</i>	<i>Tube</i>
R-f amplifier	JAN-6AB7 (V1)	A-v-c amplifier	JAN-6B8 (V8)
	JAN-6SK7 (V2)	A-n-l circuit	JAN-6AB7 (V9)
Mixer	JAN-6SA7 (V3)		JAN-6H6 (V10)
H-f oscillator	JAN-6SA7 (V4)	B-f-o circuit	JAN-6J5 (V11)
I-f amplifier	JAN-6L7 (V5)	A-f amplifier	JAN-6SC7 (V12)
	JAN-6SK7 (V6)		JAN-6V6GT (V13)
			JAN-6V6GT (V14)
Detector	JAN-6B8 (V7)	Rectifier	JAN-5Z3 (V15)

## **5. POWER REQUIREMENTS.**

This receiver may be operated from either an a-c or d-c source. For a-c operation the line voltage must be within the limits of 110 to 125 volts at 50 to 60 cycles. A-c power consumption is 138 watts for a 117-volt, 60-cycle supply. For d-c operation, a 6-volt, 4.8-ampere heater supply, and a 270-volt, 150-milliampere high-voltage supply are needed. D-c power consumption is 108 watts.

## **6. POWER OUTPUT.**

The power output of the push-pull audio amplifier is approximately 8 watts into a 5,000-ohm load.

## **7. NORMAL PERFORMANCE CHARACTERISTICS.**

**a. Sensitivity.** The sensitivity of the receiver varies between the limits of 6 to 20 microvolts for a 500-milliwatt output over the entire range of the receiver.

**b. Selectivity.** The selectivity of the receiver is determined by the band pass of the i-f circuits. The SELECTIVITY control, in conjunction with the crystal-filter circuit, provides six degrees of selectivity. The width of the band pass is variable from a few hundred cycles at SHARP CRYSTAL position, to approximately 25 kc on BROAD I.F., at 50 percent down on the selectivity curves (figs. 4 and 5).

**c. Frequency Response.** The over-all audio-frequency response with the BASS switch at the IN position, the SELECTIVITY switch at BROAD I.F., and the TONE control at 9, is flat to within 2½ decibels (db) over the frequency range of 70 to 3,000 cycles.

**d. Intermediate Frequency.** The i-f circuits are aligned to 455 kc, and the crystal filter has a natural frequency of 455 kc, plus or minus 5 kc.

# SECTION II

## INSTALLATION AND OPERATION

### 8. UNPACKING.

Carefully unpack and inspect the receiver for evidence of possible damage during shipment. Check the various controls and switches for normal ease of operation and make sure that all vacuum tubes are firmly seated in their sockets. If any control or switch binds, or there is any apparent mechanical defect, the set should be checked by experienced service personnel.

### 9. PREPARATION FOR USE.

**a. A-c Operation.** The octal shorting plug (a-c operating plug) furnished with the receiver must be inserted in the octal socket on the rear apron (fig. 2) of the receiver and the line cord connected to the line.

**b. D-c Operation.** Remove the octal shorting plug furnished with the receiver and replace it with a similar plug wired to the d-c supply as shown in figure 20.

**c. A-c Line Fuse.** Check the fuse in the a-c line circuit. Remove the holder from the fuse housing on the rear apron of the chassis (fig. 2). A spare fuse is mounted on the top of the chassis near the rectifier tube.

**d. Antenna Requirements.** This receiver will perform satisfactorily using a conventional inverted L or a doublet antenna. The reactance presented by the antenna may be cancelled by the ANT. TRIMMER control on the front panel, allowing the set to operate in conjunction with a wide variety of systems. The antenna input impedance of the receiver is 400 ohms, however, and will give maximum performance when the antenna or transmission line matches this load. For further antenna matching information see TM 11-314, section IV.

**e. Antenna Connection.** The single lead-in from an inverted L is connected to the antenna terminal marked A1. A2 is connected by a jumper wire to the ground post. The twisted pair from the doublet antenna is connected to antenna terminals A1 and A2 and the jumper to the ground terminal removed. Use this same connection for rhombic and multi-element arrays where 600-ohm transmission lines are employed.

**f. Audio Connection.** Three audio output connections are provided. The jack on the front panel is normally for headset use, and the two sets of terminals on the rear apron, marked 500 and 5000, are for use with a permanent-magnet speaker or a transmission line.

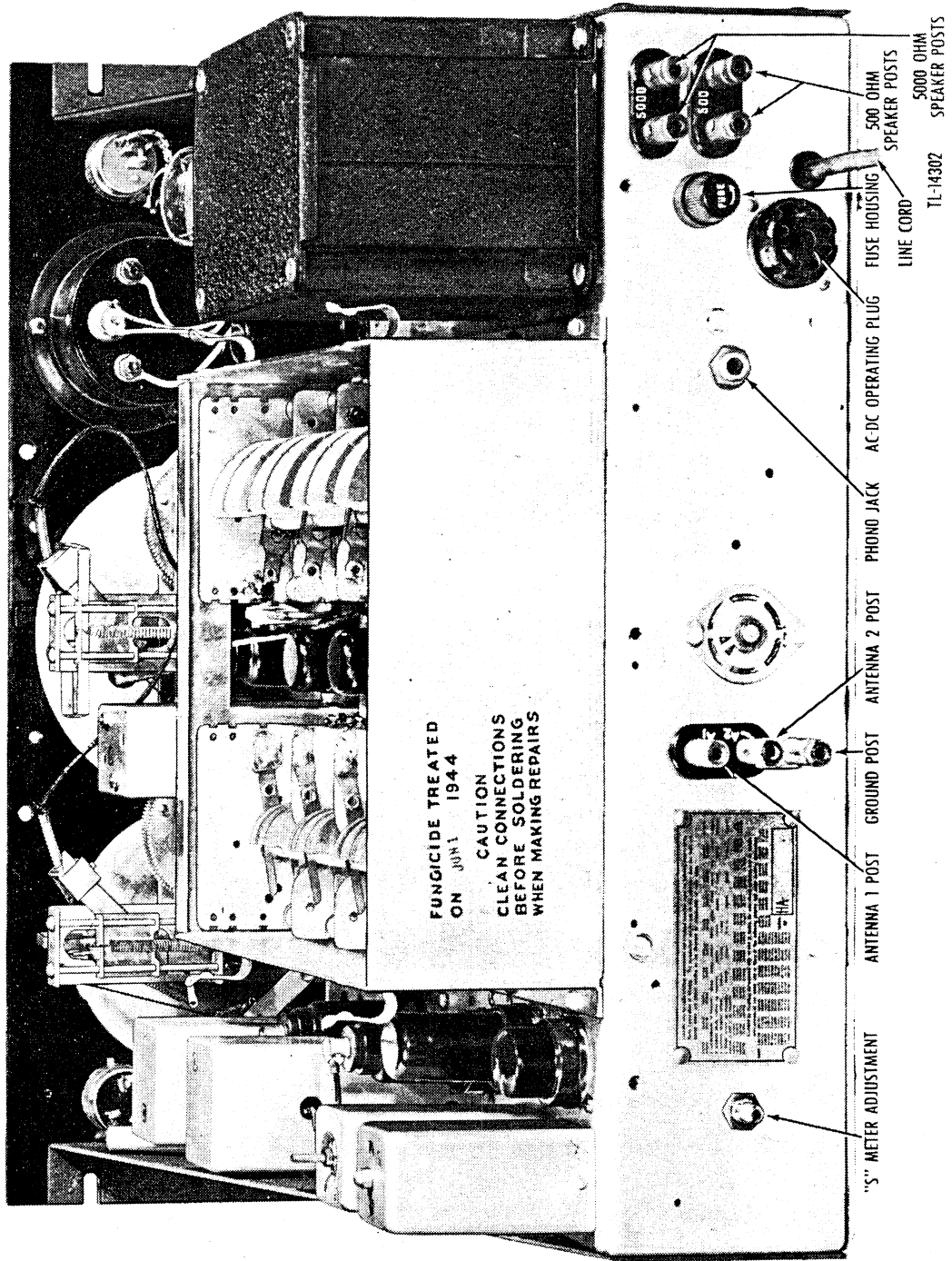

Figure 2. Radio Receiver AN/GRR-2, rear chassis apron.

## 10. OPERATION.

**a. General.** Before actual operation of the receiver is attempted, the operator should become familiar with the location of the various switches and controls.

### **b. Initial Control Settings.**

- (1) A.N.L. (automatic noise limiter) control OFF.
- (2) RECEIVE—SEND switch to RECEIVE.
- (3) SELECTIVITY control to BROAD I.F.
- (4) AVC — BFO switch to A.V.C. ON (for modulated signals) or to B.F.O. ON (for c-w signals).
- (5) R.F. GAIN control to No. 9 position.
- (6) BASS switch to IN.
- (7) Band selector to desired frequency range.

### **c. Detailed Operation.**

- (1) Turn the TONE control to the right until the a-c switch is actuated. The pilot lamps that illuminate the S meter, main tuning dial, and the band spread dial, should light. After approximately half a minute the S meter indicator needle will move to the left and signals may be tuned in.
- (2) For operation on the two lowest frequency bands, set the band spread tuning dial to 100 on the 0 to 100 scale, and use only the main tuning dial and knob to tune in the desired signal.
- (3) For operation on the four highest frequency bands, set the main tuning dial to a point slightly higher in frequency than the desired signal and then use the band spread knob to tune in the signal. If the frequency of the desired signal falls within the limits of the frequency calibrations on the band spread dial, the indicated frequency will be correct only if the main tuning dial is preset to the calibration point for that band. These calibration points are indicated by four small circles (one for each of the four bands) on the main tuning dial and marked consecutively, 10 M, 20 M, 40 M, and 80 M in RED directly under the circle, starting with the highest frequency band.
- (4) After the signal has been tuned in, adjust the ANT. TRIMMER control for maximum deflection on the S meter.
- (5) Adjust the TONE control and BASS switch to emphasize bass or treble frequencies, as desired.
- (6) Adjust the A.F. GAIN control for the desired volume.
- (7) The R.F. GAIN control is normally set at position No. 9 to increase the signal to noise ratio. In some instances it may be necessary to reduce this setting to prevent the receiver from being blocked by strong signals.



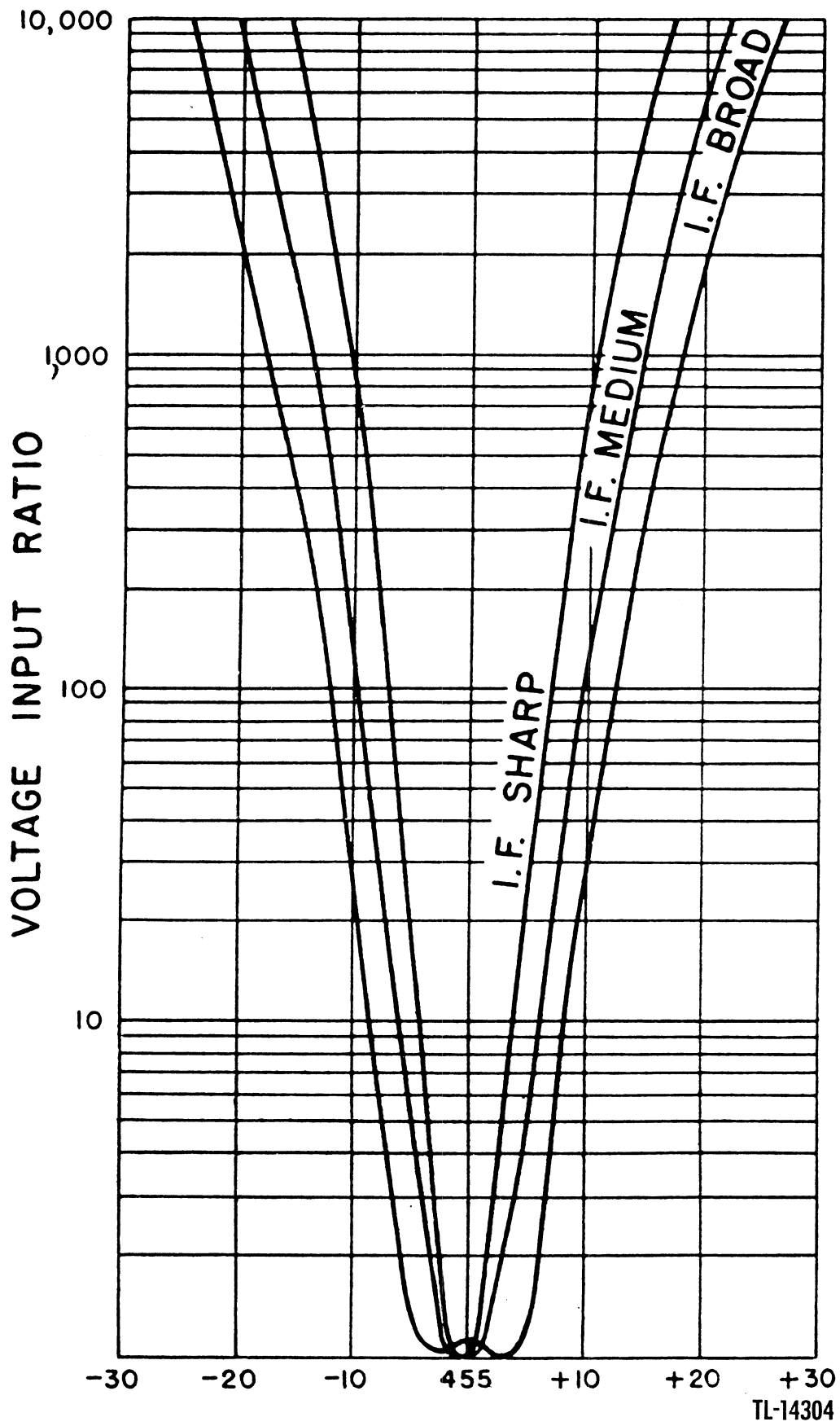

Figure 4. I-f selectivity curves without crystal filter.

(8) The AVC — BFO switch is normally used in the A.V.C. ON position for modulated signals. For weak signals, however, the A.V.C. OFF position will give slightly greater sensitivity.

(9) The B.F.O. control varies the frequency of the audio output when the AVC — BFO switch is to B.F.O. ON position and a signal is tuned in.

(10) The RECEIVE — SEND switch must be in the RECEIVE position to operate the receiver, but may be placed in the SEND position if the receiver is not needed for short periods. In the SEND position the heaters remain at operating temperature. Only the high voltage is removed from the receiver circuits.

(11) The A.N.L. control is used to reduce electrical or ignition noises. Normally the control is left in the O position.

(12) The SELECTIVITY control is used to reduce signal interference. Three positions place the i-f crystal filter in the circuit. The other three positions do not. Whenever possible, the BROAD I.F. position should be used for voice reception, since the fidelity of the receiver is decreased as the selectivity is increased. For c-w reception any position of the control may be used to increase the selectivity. Figures 4 and 5 show the selectivity curves for the six positions.

(13) The CRYSTAL PHASING control is used when the SELECTIVITY control is in any one of the three crystal positions. The control minimizes interference caused by high-frequency noises, and in conjunction with the crystal filter reduces signal interference. As the receiver is tuned across a signal, the amplitude will appear greater on one side of zero-beat. Tune to the weaker side and adjust the CRYSTAL PHASING control until the signal is reduced in amplitude as much as possible (fig. 6). This will be the correct setting of the phasing control for any other signal, providing the selectivity control is not changed.

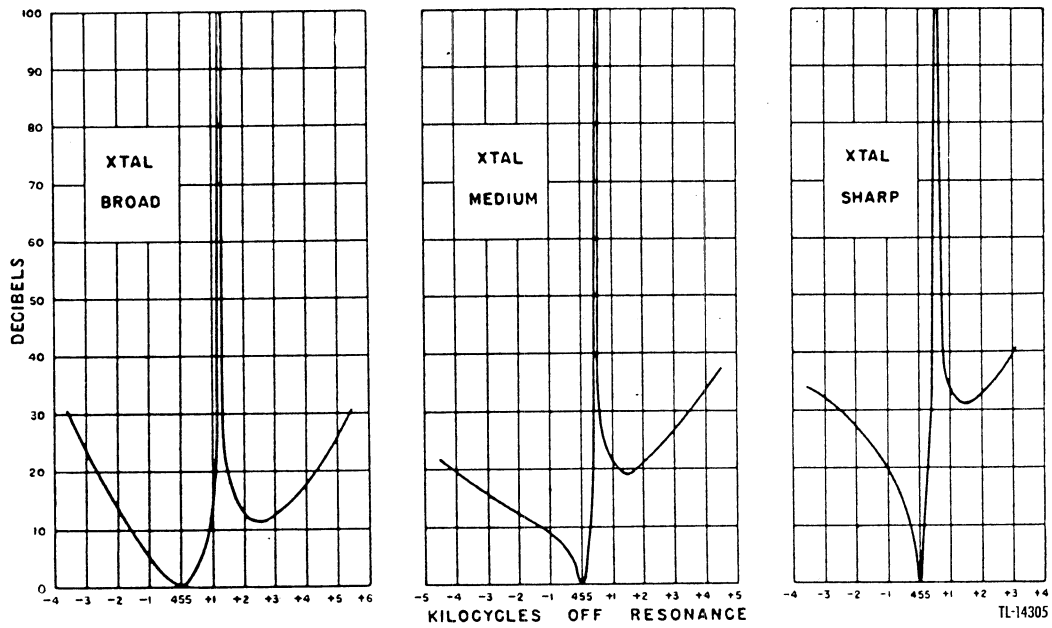

Figure 5. Crystal selectivity curves.

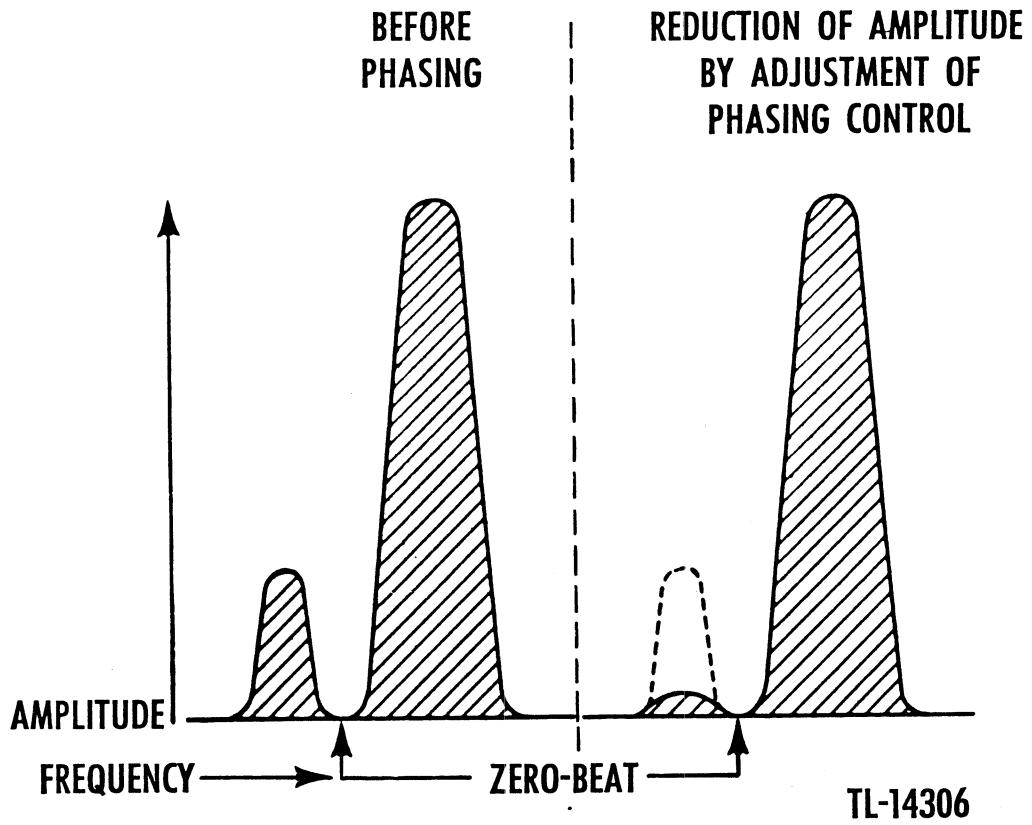

Figure 6. Effect of correct adjustment of crystal phasing control.

# SECTION III

## FUNCTIONING OF PARTS

### 11. GENERAL.

Figure 7 is a block diagram showing the progress of the signal through Radio Receiver AN/GRR-2 with its associated control circuits. Figure 8 is a view of the interior of the receiver with the function of each tube indicated. The signal picked up by the antenna is fed to the first r-f amplifier. This stage is not used when operating on bands 1 and 2. From this stage the signal is passed through the second r-f stage for further amplification and fed to the mixer tube. Here the signal combines with the output of the high-frequency oscillator producing the intermediate frequency. The output of this stage feeds three circuits: the first i-f amplifier, the noise amplifier, and the automatic-volume-control amplifier. The noise amplifier and associated noise rectifier apply an instantaneous cut-off grid bias to the first i-f amplifier upon receiving high amplitude transient noise impulses. The a-v-c amplifier and rectifier return a biasing voltage to the r-f stages and converter stage proportional to the magnitude of the received signal. The signal progresses through the first and second i-f amplifier stages in succession and passes to the detector where rectification occurs. An a-v-c voltage developed here is used to control the sensitivity of the first i-f stage. For c-w signals, the beat-frequency oscillator produces a heterodyning frequency which combines with the converted signal in this detector stage to produce an audible note. A d-c amplifier, using the d-c component of the signal, is provided to actuate the S meter. The output of the detector passes to the first and second audio amplifiers, and to the audio output connections.

### 12. R-F AMPLIFIER (fig. 9).

The r-f amplifier or preselector uses two tubes in cascade on bands 3, 4, 5, and 6. On bands 1 and 2 only one stage of r-f amplification is used. Two stages are used on the high-frequency bands to provide satisfactory image rejection. Signals present in the antenna circuit are fed to the primary of r-f transformer T9, T10, T11, or T12 for operation on bands 3, 4, 5, or 6, depending on the position of the band selector switch SW8-2. The proper secondary of these r-f transformers is selected by switch SW8-3, tuned by the ganged variable capacitor C2.3, and shunted by the ganged variable capacitors C3.3, C4.3, or C5.3 depending on the position of switch SW8-4. Both switches SW8-3 and SW8-4 are units of the main band selector switching assembly. Variable

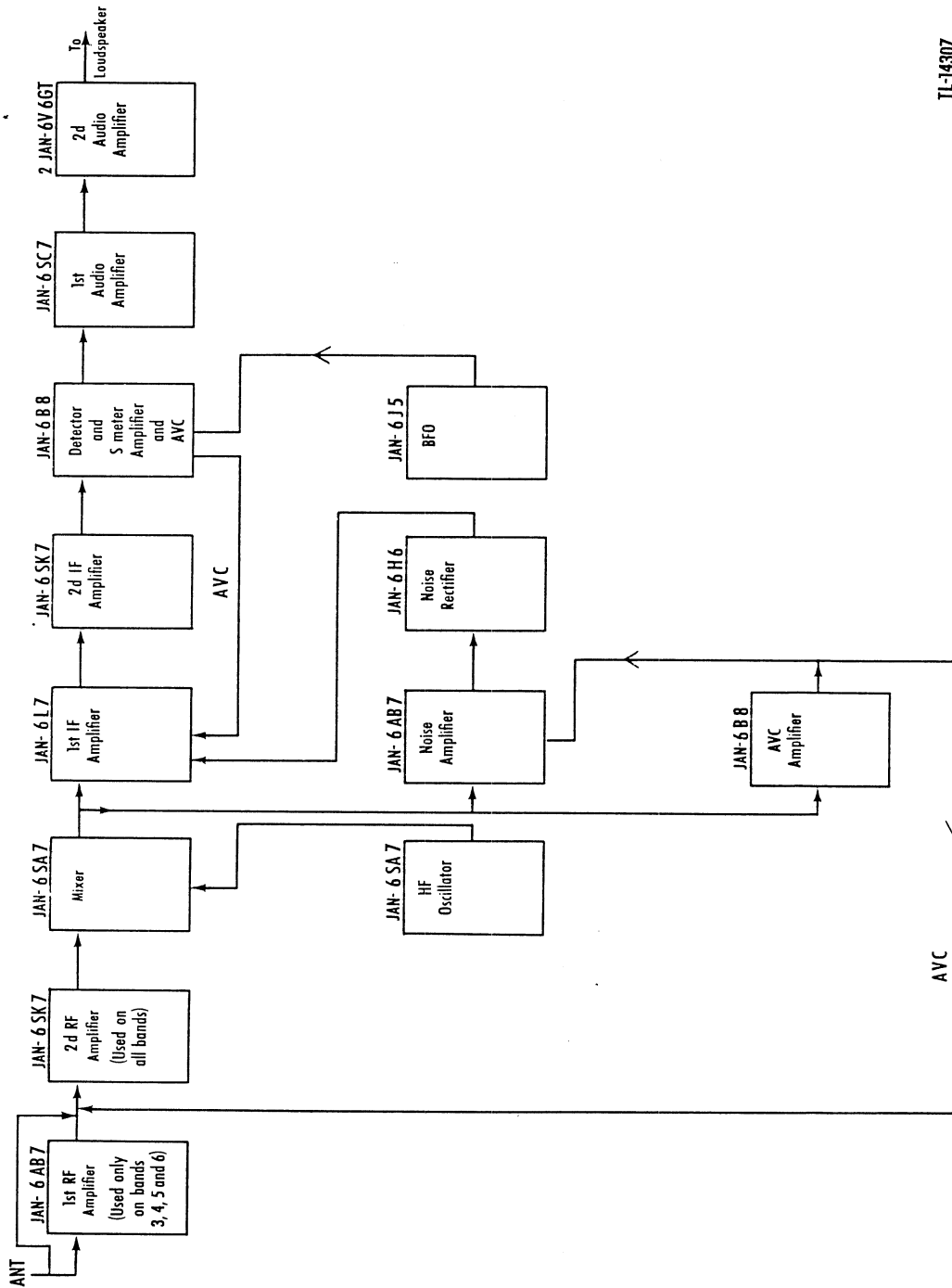

TI-14307

Figure 7. Radio Receiver AN/GRR-2, block diagram.

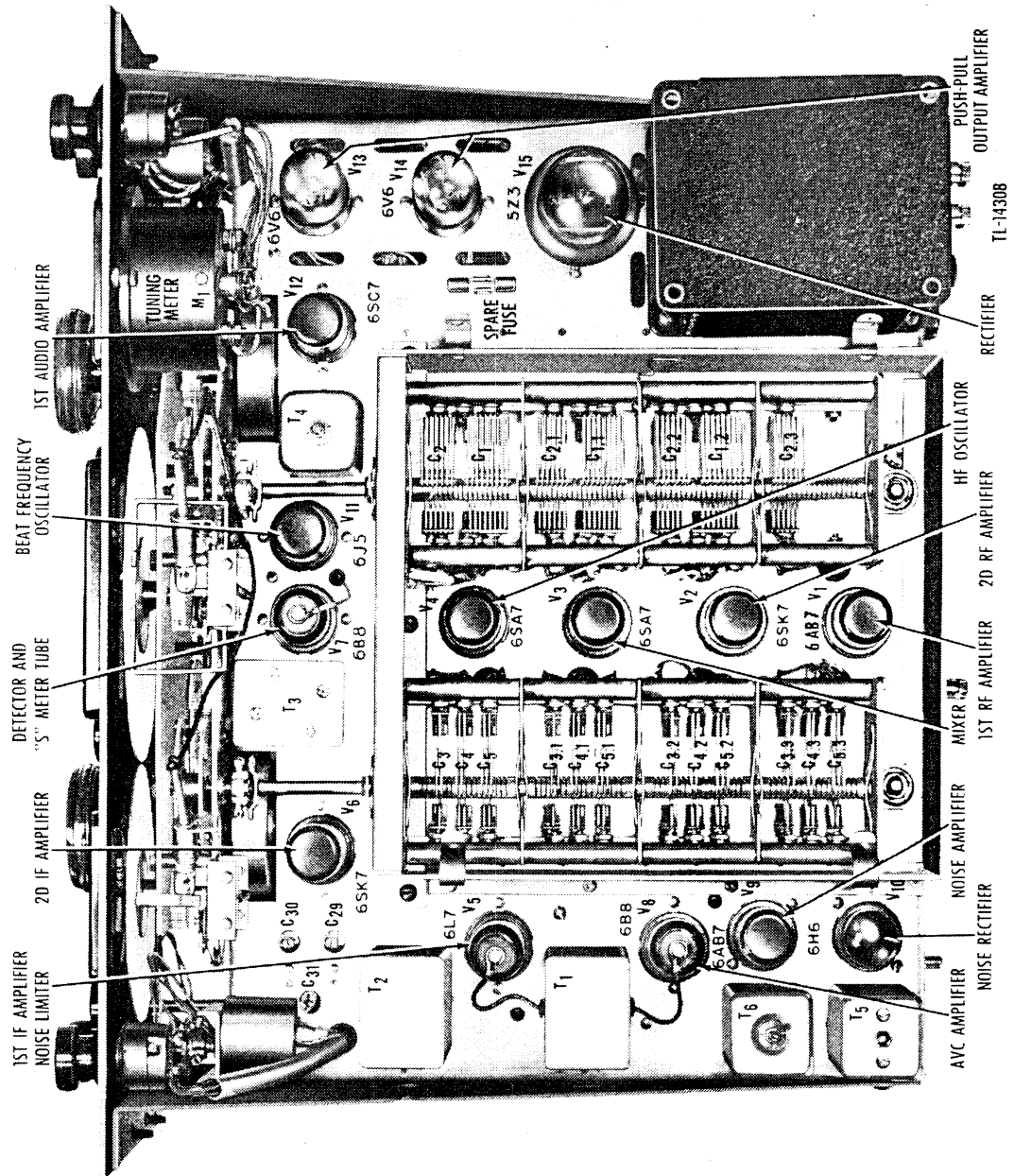

capacitor C6 shunts the secondary of the r-f transformer in use and provides a means for balancing out the reactance reflected by an improperly matched antenna. Switch SW8-1 places this capacitor across the input circuit of Tube JAN-6AB7 (V1) on bands 3, 4, 5, and 6 and across the input to the Tube JAN-6SK7 (V2) for bands 1 and 2. This capacitor is adjusted by means of the control marked ANT. TRIMMER on the front panel of the receiver. The antenna signal is transferred to the primary of the r-f transformer T13 for band 1 operation (0.55 mc to 1.6 mc) and to the primary of r-f transformer T14 for operation on band 2 (1.6 mc to 3.0 mc) by switch SW8-2. Resistor R1 is used for a-v-c decoupling and capacitor C77 serves to ground the grid return of Tube JAN-6AB7 (V1) to the signal voltage. Resistor R7 and capacitor C17 have the same function for the second r-f stage. Resistor R74 prevents parasitic oscillation and tends to stabilize the amplifier. Resistor R3 in series with the r-f gain control R2 provides minimum self bias for the first r-f stage. Capacitors C14 and C87 filter this bias voltage. Resistor R8 and capacitors C18 serve similar purposes for Tube JAN-6SK7 (V2). Screen grid voltage for tube V1 is supplied through dropping resistor R4 while capacitor C15 bypasses r-f voltage to ground. Resistor R9 and capacitor C19 function in a similar manner in the screen grid circuit of tube V2. The amplified signal output from tube V1 on bands 3, 4, 5, or 6, energizes the primary of transformer T15, T16, T17, or T18 depending on the position of band switch SW8-5. The plate of this tube receives its positive potential from the power supply through dropping resistor R5 and capacitor C16 bypasses r-f voltage to ground. Resistor R67 is used as the plate load on band 1, while resistor R72 serves the same purpose on band 2. Although tube V1 is inoperative as an amplifier on these bands, it is supplied with operating voltages to maintain a constant drain on the power supply, and thus prevent voltage fluctuations when changing bands. Switch SW8-6 selects the proper secondary of r-f transformers T13, T14, T15, T16, T17, or T18. The main ganged tuning capacitor C1.2 is shunted by ganged capacitor C2.2, C3.2, C4.2, or C5.2 as controlled by switch SW8-7. Transformers T15, T16, T17, and T18 have special factory-adjusted and sealed iron cores as well as adjustable trimmers C88, C89, C90, and C91. The two low-frequency bands do not require these adjustments. The signal is amplified by tube V2 and energizes the primary of the proper r-f transformer through the action of switch SW8-8. Capacitive in addition to inductive coupling is provided on band 5 by capacitor C83, while C114 serves the same purpose for band 2. Resistor R10 is the

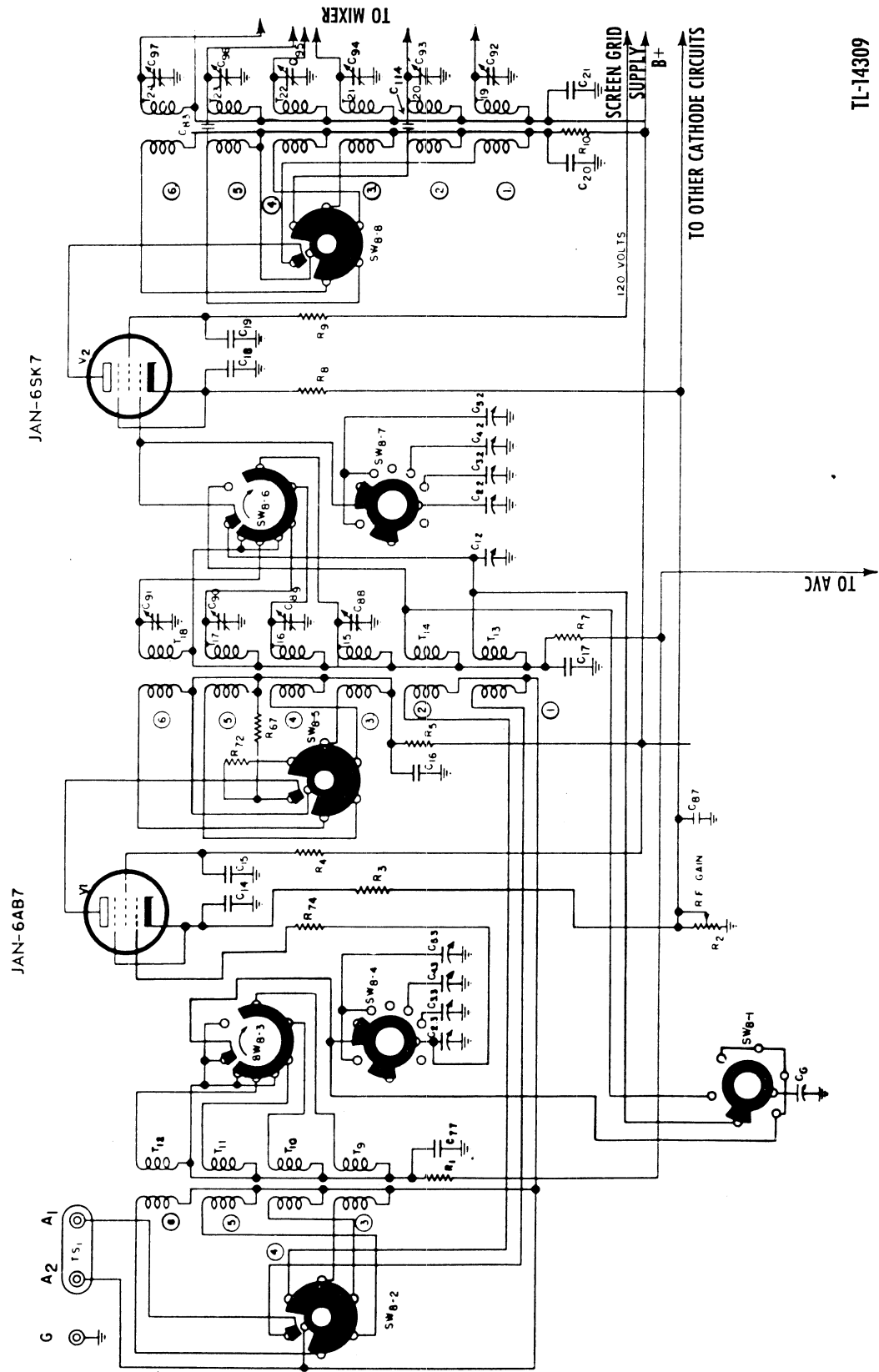

Figure 9. R-f amplifier, schematic.

plate-dropping resistor and capacitor C20 bypasses r-f voltage to ground. The r-f transformers associated with the output of tube V2 have adjustable iron cores which have been accurately adjusted and sealed at the factory and require no further adjustment.

### 13. MIXER (fig. 10).

The mixer stage utilizes a pentagrid converter Tube JAN-6SA7 (V3) which, in conjunction with the h-f oscillator, converts the incoming signal to an intermediate frequency of 455 kc. Switch SW8-9 selects the r-f transformer secondary being used while switch SW8-10 connects the ganged capacitors C2.1, C3.1, C4.1,

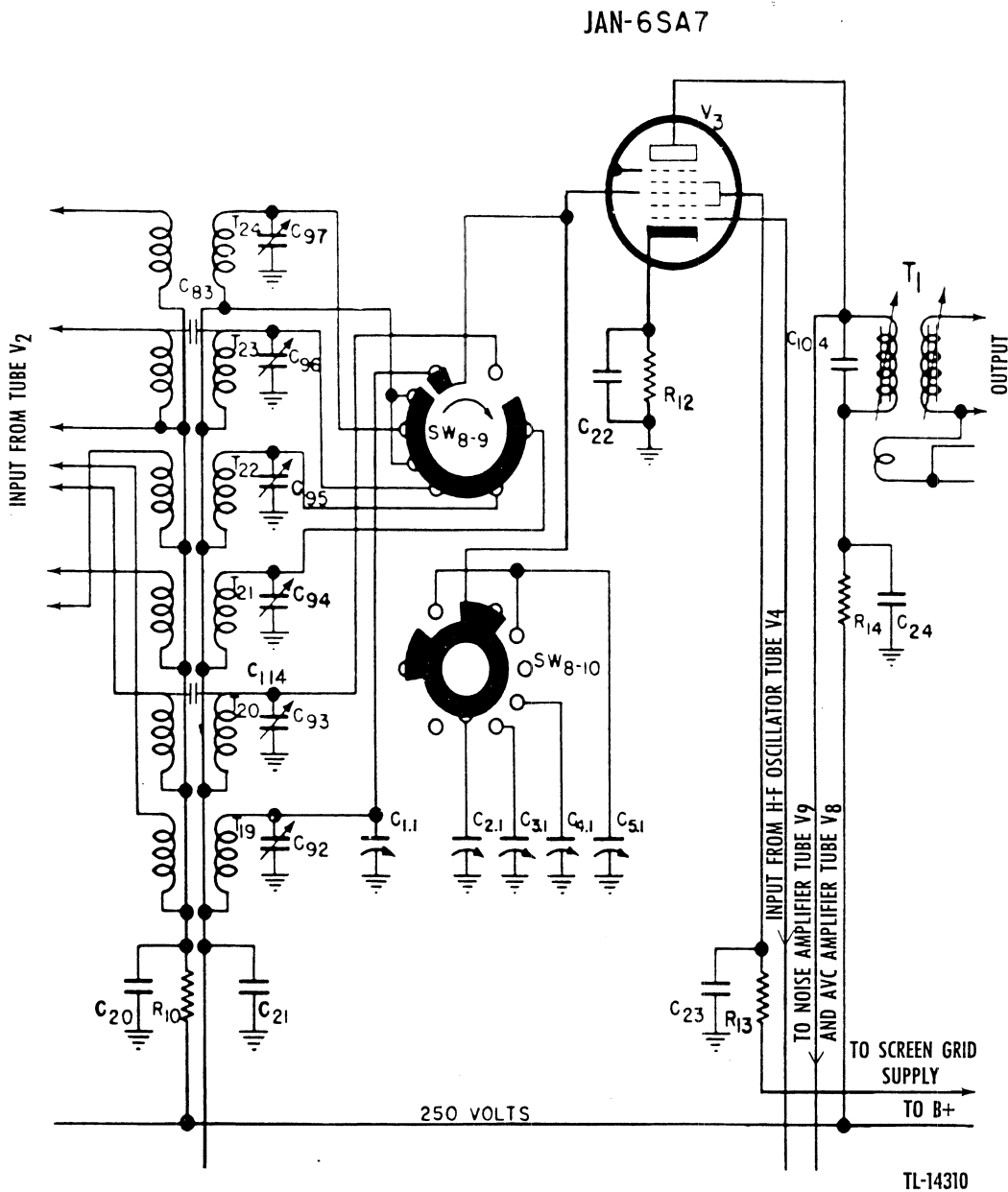

Figure 10. Mixer stage, schematic.

or C5.1 across the ganged main tuning capacitor C1.1. Both switch SW8-9 and switch SW8-10 are part of the band switch. Resistor R11 and capacitor C21, form an a-v-c decoupling network. Resistor R12 is the cathode self-biasing resistor filtered by C22. Grid number 1 acts as the injection grid, receiving its energy from the h-f oscillator Tube JAN-6SA7 (V4). Resistor R13 is the screen-dropping resistor and capacitor C23 bypasses r-f voltage. The output of the mixer tube is fed to the primary of transformer T1, which is permeability tuned to 455 kc in conjunction with capacitor C104. Plate potential is supplied through dropping resistor R14 and capacitor C24 bypasses r-f voltage. The output of this stage also feeds the a-v-c amplifier Tube JAN-6B8 and the noise amplifier Tube JAN-6AB7.

#### 14. H-F OSCILLATOR (fig. 11).

A separate Tube JAN-6SA7 (V4) is used as the high-frequency oscillator and produces a frequency 455 kc above the received signal. The h-f oscillator signal is coupled to the No. 1

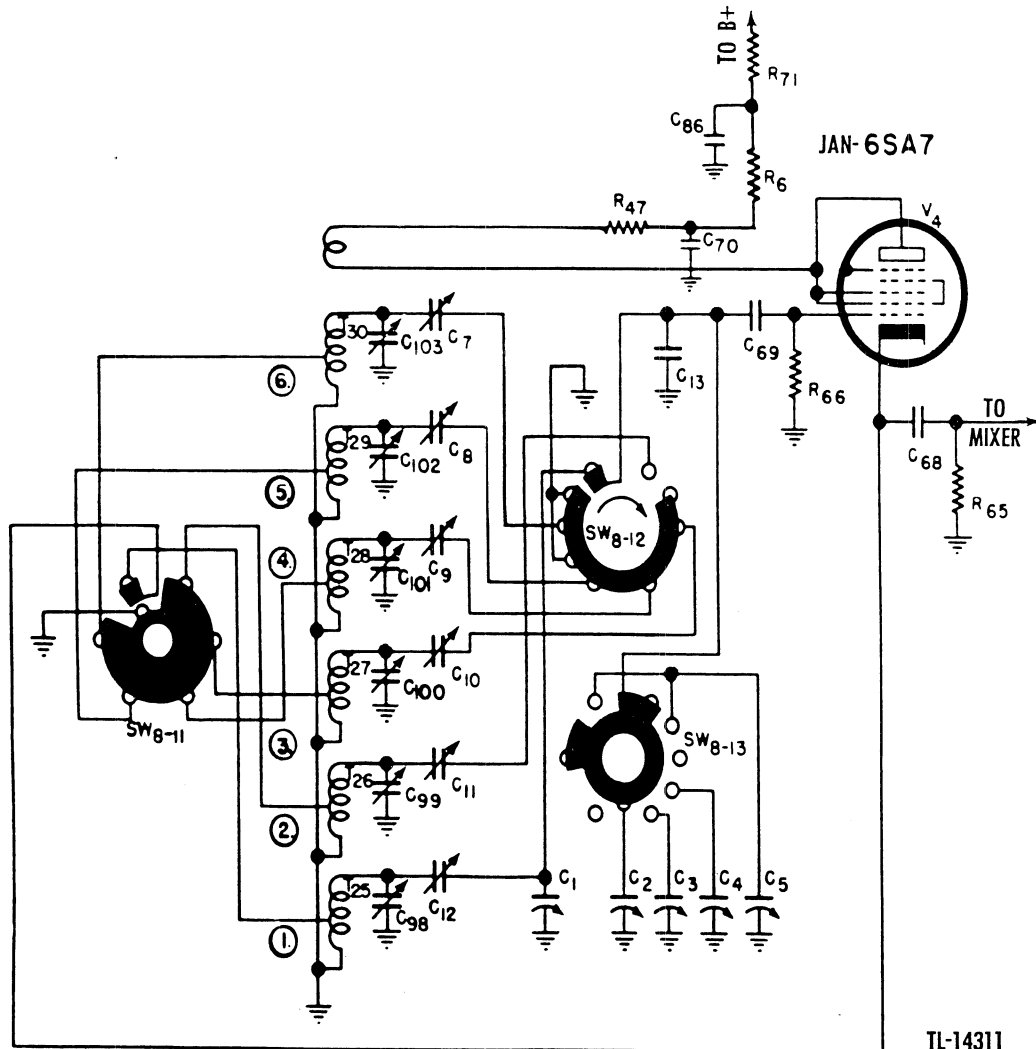

Figure 11. High-frequency oscillator, schematic.

grid of the mixer Tube JAN-6SA7 (V3) through capacitor C68 and across resistor R65. Switches SW8-11 and SW8-12 select the proper oscillator coil for the band being used. Switch SW8-13 shunts the proper ganged tuning capacitor C2, C3, C4, or C5 across the main tuning capacitor C1. Trimmers C98, C99, C100, C101, C102, and C103 across their respective coils are adjusted during the alignment procedure. Low-frequency padders C7, C8, C9, C10, C11, and C12 are adjusted at the factory and need no further adjustment. The grids, numbers 2, 3, and 4, are connected to the plate and all operate at the plate potential. This potential is supplied through dropping resistor R71, decoupling resistor R6, and parasitic suppressor R47. R-f voltages are bypassed to ground by capacitors C70 and C86. Capacitor C13 is a temperature compensating capacitor providing oscillator stability. Bias is developed across grid leak resistor R66 charging blocking capacitor C69 negative on the grid side.

#### **15. I-F AMPLIFIER (figs. 12 and 13).**

**a.** The i-f amplifier consists of transformers T1, T2, and T3; tubes V5 and V6; and associated components. Permeability tuning is used in transformers T1 and T2 to provide increased gain and stability.

**b.** Fixed capacitors C104 and C105 plus the permeability tuned coils resonate the primary and secondary of T1 to the intermediate frequency. The bandwidth of transformers T1 and T2 is broadened by inclusion in the circuit of additional inductance controlled by switches SW9-1, and SW9-2 (fig. 12) which works in conjunction with SW9-3 (fig. 13).

**c.** Resistor R15 and capacitor C25 are the a-v-c decoupling resistor and bypass capacitor respectively. Self bias is obtained for Tube JAN-6L7 (V5) through a switching arrangement controlled by SW8-14. Resistor R68 in series with resistor R16 and the r-f gain control R2 are used in the cathode circuit on band 4; resistors R26, R16, and R2 are in series for bands 3 and 5; resistors R16 and R2 are used for bands 1, 2, and 6. Capacitor C26 filters each of these combinations. Screen-grid voltage for tube V5 is supplied through dropping resistor R17 filtered by capacitor C27. Capacitor C106 resonates the primary of T2 to the intermediate frequency. Plate voltage for tube V5 is obtained through dropping resistor R18, and capacitor C28 bypasses r-f voltage. The following six ranges of selectivity are provided in the second i-f circuit.

- (1) BROAD I.F. (for high-fidelity reception).
- (2) MED. I.F. (more selectivity, less highs).
- (3) SHARP I.F. (reduces interference, far less highs).

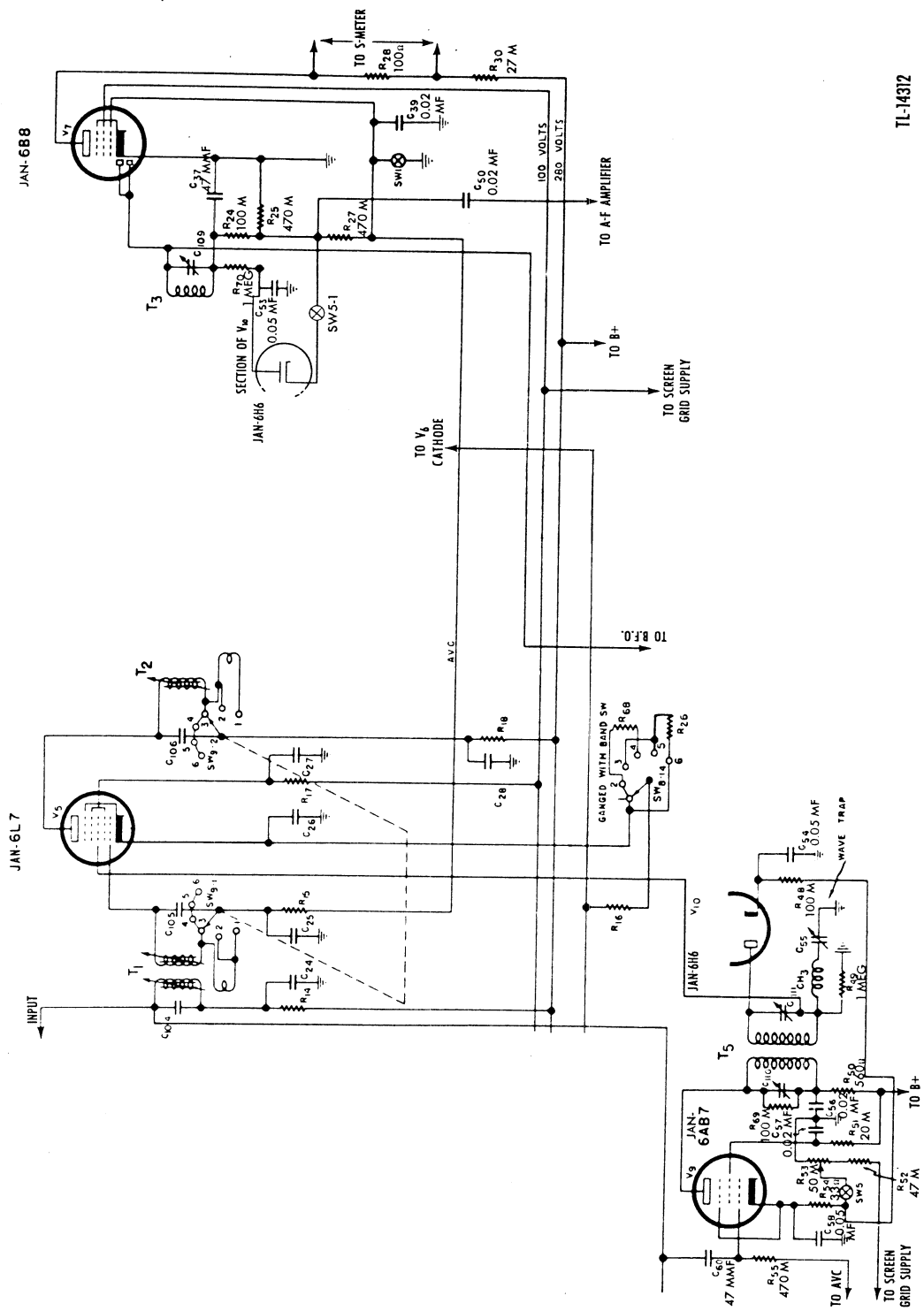

TL-14312

Figure 12. First i-f amplifier, detector, and A.N.L., schematic.

- (4) XTAL BROAD (similar to sharp i.f. but sharper cutting of side bands).
- (5) XTAL MED. (next selectivity step after (subparagraph (4) above), greatly increased side band cutting, more pronounced crystal filtering of interference, very few high-frequency components present).
- (6) XTAL SHARP (position of extreme selectivity, practically no side bands, very pronounced crystal filtering).

d. The graphic effects of the different steps of selectivity on a signal are shown in figures 4 and 5. The crystal filter circuit is effectively a series resonant circuit which readily conveys all signals of the crystal frequency to the grid of the next tube. However, to frequencies slightly higher than the crystal frequency, the crystal and holder form a parallel resonant circuit which opposes the transfer of signal. Thus the crystal only transfers signal on the low-frequency side of the series resonant frequency of the crystal circuit. The bandwidth of the crystal and transformer secondary circuits can be varied by shifting the resonant frequency of the transformer secondary.

e. In positions 1, 2, and 3 of switch SW9-3 (fig. 13) the crystal

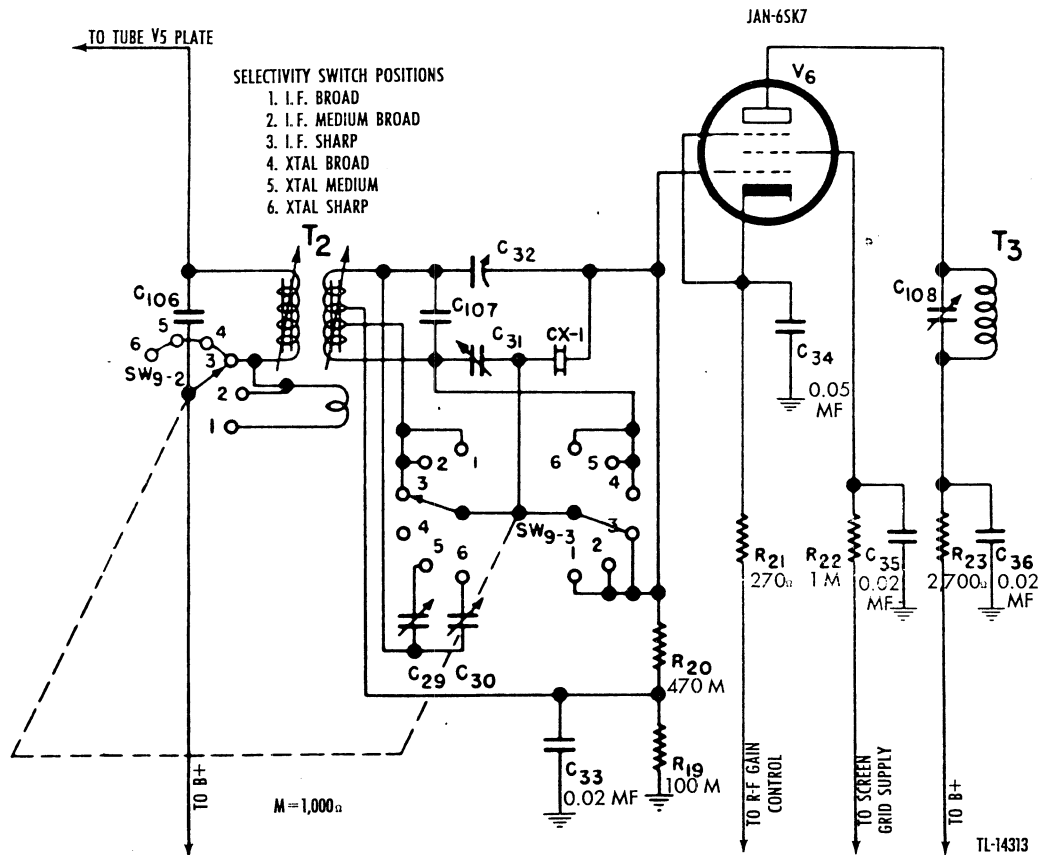

Figure 13. Crystal filter and second i-f amplifier, schematic.

is short-circuited. In position 4 the short across the crystal CX-1 is opened and the iron core in the secondary of transformer T2 has been adjusted for broad crystal action and at this point is accurately tuned to the crystal frequency. Because of the close coupling of the secondary to the crystal, the sharply rising resonance curve of the crystal causes, in contrast, a sharply falling resonance curve in the secondary. The combined action of these two characteristics results in a relatively broad resonance curve for the crystal broad selectivity setting. In the MED. XTAL, No. 5, position, C29 is adjusted for selectivity midway between the broad and crystal sharp settings.

f. In position 6, or XTAL SHARP, the trimmer C30 (fig. 13) has been adjusted for the sharpest crystal action. Under this condition, the secondary is slightly detuned from the resonant crystal frequency sufficiently so that its resonance curve is not greatly affected by the crystal but still coupled tightly enough so that it can transfer energy to the crystal circuit. As this point was reached, it was indicated by a rise in the output. Two such points of increased output will normally occur—one for each adjustment of the secondary on either side of the resonant frequency of the crystal.

g. Capacitor C107 tunes the secondary of i-f transformer T2 to the intermediate frequency. The crystal filter comprises a balanced capacity bridge circuit consisting of capacitors C31, C107, C32, and the capacity of the crystal CX-1. Resistors R20 and R19 act as grid return for tube V6, the latter resistor being filtered by capacitor C33. Cathode bias for this tube is provided by resistors R21 and R2 filtered by capacitors C34 and C87. Resistor R22 is the screen-dropping resistor and capacitor C35 bypasses r-f voltage. The output of the tube is fed to the second detector through transformer T3, the primary of which is tuned to the intermediate frequency by capacitor C108. Tube V6 receives its plate potential through dropping resistor R23 and capacitor C36 bypasses r-f voltage.

#### **16. DETECTOR (fig. 12).**

A twin diode pentode Tube JAN-6B8 (V7) is used as detector and S meter amplifier. The i-f signal is fed to the diode plates from the secondary of transformer T3 tuned by capacitor C109. Resistors R24 and R25 form the diode load across which the a-v-c voltage for the first i-f amplifier is developed. Capacitor C37 bypasses the i-f component from this voltage. Capacitor C39 is the r-f bypass across the pentode section, and the control grid return consists of resistors R27 and R25. The junction of these two resistors couples to the audio amplifier through capacitor

C50. Switch SW1 grounds the input to the pentode section of tube V7, making the S meter inoperative when the A.V.C.-B.F.O. switch is in the A.V.C. OFF or B.F.O. ON position. The screen grid of this tube is directly connected to the screen grid voltage divider consisting of resistors R31 and R32. Plate voltage is supplied through dropping resistor R30, the S meter, and shunt resistor R28. The S meter zero set rheostat R29 (fig. 27) is adjusted by a control located on the rear chassis apron.

#### 17. NOISE LIMITER (fig. 12).

a. Two noise-limiting circuits are used in the receiver. One circuit provides for the shunting of the detector diode load with a capacitor to momentarily bypass audio signals, the other places a negative potential on the number 3 grid of the first i-f amplifier tube. When a signal is applied to the detector, a charge appears on capacitor C53 proportional to the flow of rectified carrier current through the detector diode load resistors R24 and R25. Thus a negative potential appears on the plate of the limiter diode, upper section of Tube JAN-6H6 (V10) (fig. 12). Upon application of a sharp noise signal, an instantaneous negative voltage appears on the cathode of the limiter diode before capacitor C53 can charge through the 1-megohm resistor R70. Thus the diode conducts and effectively places capacitor C53 across the portion of the load resistor from which the a-f voltage is taken, bypassing the higher audio frequencies.

b. The second noise-limiting circuit receives a signal from the plate of tube V3 through capacitor C60. The signal is amplified by the noise amplifier Tube JAN-6AB7 (V9) and applied to one section of tube V10 functioning as noise rectifier. When the noise impulses exceed the potential developed across cathode resistor R54 by the flow of bleeder current from the screen voltage supply line, the noise rectifier conducts. The flow of rectified current through resistor R49 places a negative potential on the number 3 grid of the i-f amplifier tube V5. Grid bias for tube V9 is developed across resistor R54 and a-n-l control R53, when switch SW5 is on. Capacitor C58 filters this bias. Bias voltage for the grid of tube V9 is also supplied by the a-v-c amplifier tube V8 (fig. 14) through decoupling resistors R55 and R57 and is filtered by capacitor C59 (fig. 27). Resistor R55 is the grid return load resistor. Screen-grid voltage is obtained through dropping resistor R51 bypassed by capacitor C57. A broadly tuned i-f transformer T5 is used in the plate circuit of tube V9, the secondary feeding into the section of tube V10 which functions as a noise rectifier. Resistor R69 across capacitor C110 broadens the frequency response of this circuit. A wave trap consisting of choke CH3 and

capacitor C55, connected in parallel with diode load resistor R49, provides a low impedance path to ground for i-f signals. Bias for the noise rectifier section of tube V10 is supplied through the a-n-l control R53 and resistor R48 and filtered by capacitor C54. By varying the a-n-l control R53, the negative voltage applied to tube V5 is varied until it is sufficient to reduce the amplification of tube V5 for the duration of the noise signal.

c. If the noise limiter adjustment permits too great a value of negative voltage to be applied to the injector grid of tube V5, distortion will appear in the output of the receiver. If, on the other hand, not enough noise voltage is applied, the momentary decrease in sensitivity will not be great enough to stop the noise from getting through. Some of it will appear in the plate circuit of the tube and consequently in the output of the receiver. Therefore, the noise limiter must be carefully adjusted to the particular carrier and noise level being received.

### 18. A-V-C AMPLIFIER (figs. 14 and 15).

A double a-v-c system is used. In the first system the signal voltage is taken off the output of the mixer and applied to the a-v-c amplifier and rectifier. The output of the diode rectifier con-

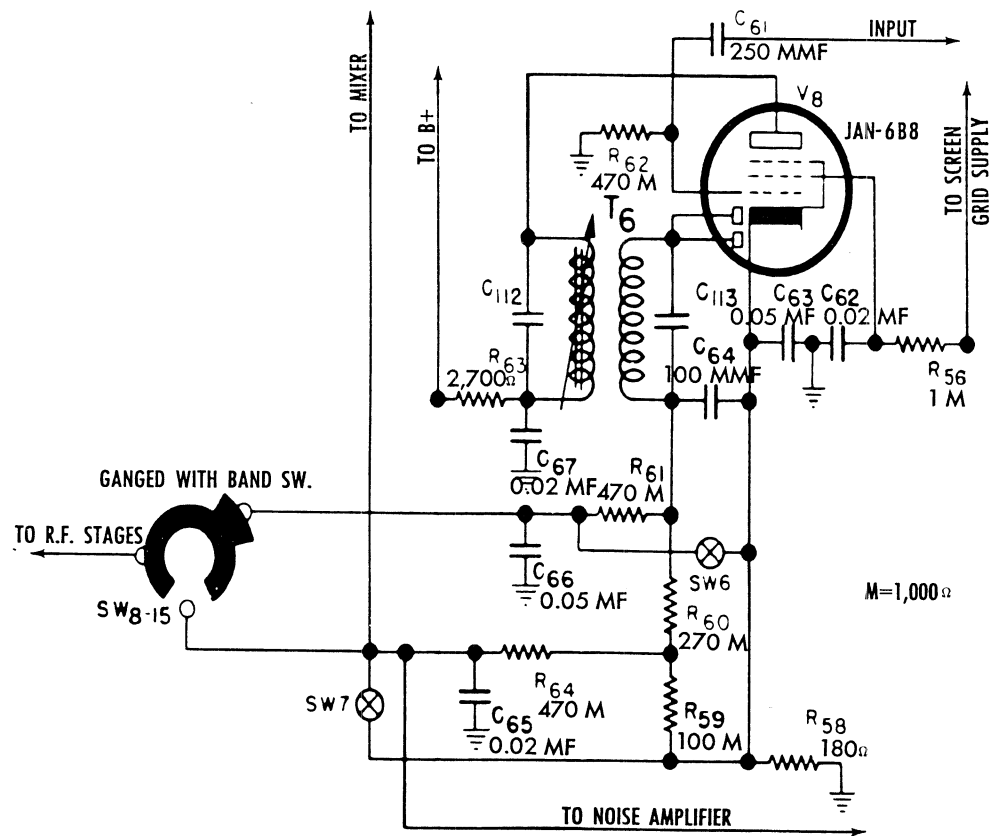

TL-14314

Figure 14. Automatic-volume-control amplifier, schematic.

trols the gain of the r-f amplifiers and the mixer. A signal from the plate circuit of tube V3 is applied to the control grid of tube V8 through capacitor C61 and across grid load resistor R62. Bias voltage for the pentode section of tube V8 is developed across

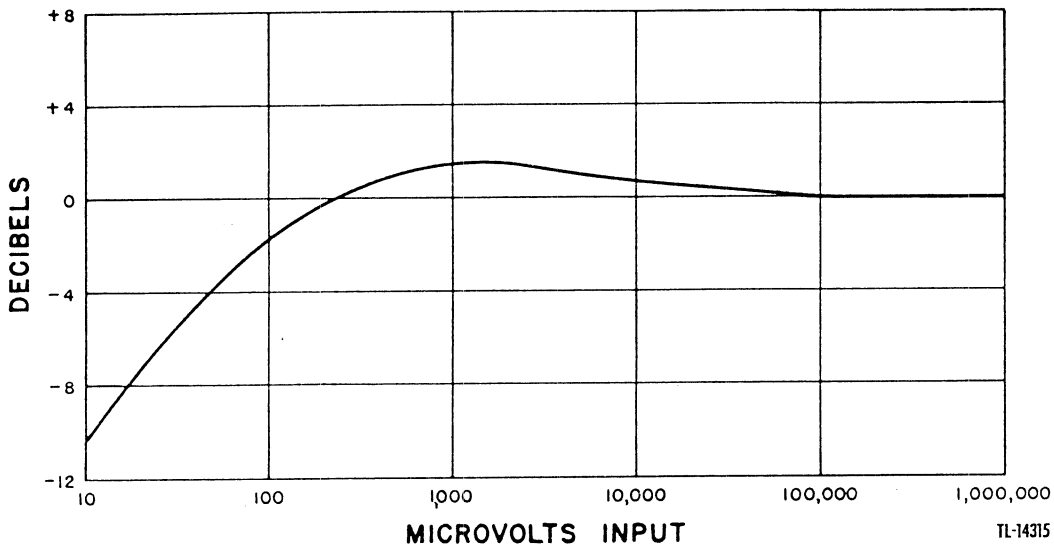

Figure 15. A-v-c curve taken at 3 megacycles.

resistor R58 and filtered by capacitor C63. Screen-grid voltage is supplied through resistor R56 and r-f voltage is bypassed by capacitor C62. Plate voltage is supplied through the primary of transformer T6 and the decoupling network consisting of resistor R63 and capacitor C67. Transformer T6 transfers the signal from the plate circuit to the diodes of tube V8 for rectification. Capacity for resonating the coils of transformer T6 is provided by fixed capacitor C112 used with the permeability tuned primary, and fixed capacitor C113 used with the secondary. The a-v-c voltage appears across resistors R59 and R60 and is filtered by capacitor C64. Resistor R61 and capacitor C66 comprise the isolating network for the r-f stages when operating on band 1, while resistor R64 and capacitor C65 serve the same purpose for the mixer stage which receives a lower value of a-v-c voltage. This lower value of a-v-c voltage is obtained from the junction of resistors R59 and R60. On bands other than band 1, switch SW8-15 connects the r-f stages to receive the same value of a-v-c voltage as the mixer stage. Switches SW6 and SW7 removes a-v-c voltage from these stages by connecting this voltage to the cathode of tube V8 when the AVC — BFO switch is in the A.V.C.—OFF position. In the second system the a-v-c voltage is taken off the diode detector load resistor and controls the gain of the first i-f amplifier. This voltage is taken from the junction of

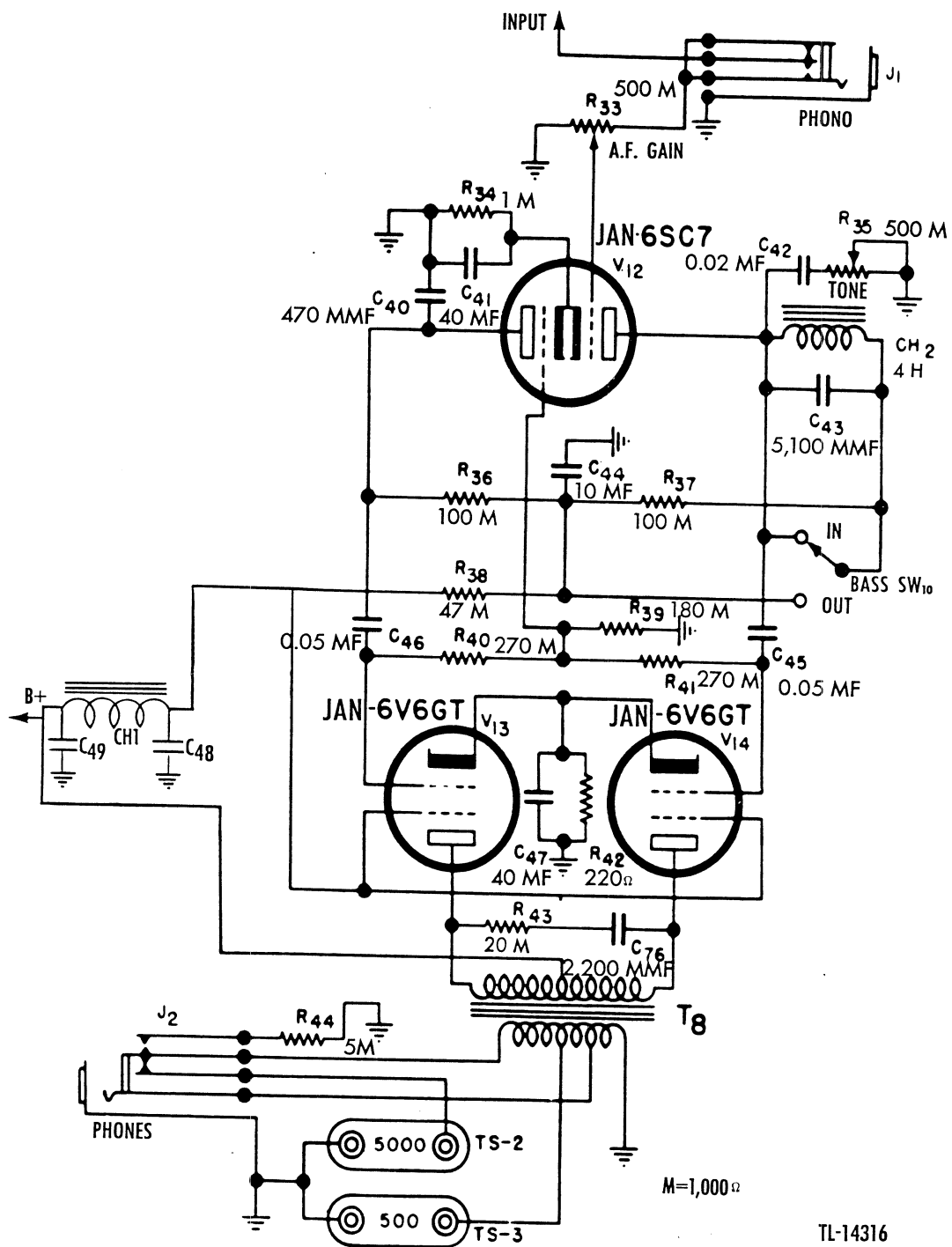

Figure 16. Audio amplifier, schematic.

the diode detector load resistors R24 and R25. This voltage is applied to the grid of tube V5 through resistor R27, the decoupling network consisting of resistor R15 and capacitor C25, and the secondary of transformer T1.

#### **19. AUDIO AMPLIFIER (fig. 16).**

**a.** The audio amplifier consists of a phase-inverter Tube JAN-6SC7 (V12) and two output Tubes JAN-6V6GT (V13 and 14) in push-pull. An a-f signal from the detector is applied to the grid of the first section of twin triode tube V12 through phono jack J1 and a-f gain control R33. The output signal from the first section of tube V12 is applied to the grid of tube V14 through capacitor C45. This signal also appears across the series resistance path consisting of resistors R41 and R39. The portion of this signal voltage appearing across resistor R39 provides grid excitation for the second section of tube V12. The plate circuit of this section of tube V12 provides, through capacitor C46, a signal for the grid of tube V13 which is opposite in polarity, at any instant, to the signal applied to the grid of tube V14. This signal voltage also appears across resistors R40 and R39. Resistors R40 and R41 are equal in resistance value. As the signal applied to the grid of tube V14 becomes greater than the signal applied to tube V13, the polarity of the instantaneous voltage developed across resistor R39 is such as to cause greater instantaneous output from the second section of tube V12. The grids of tubes V13 and V14 are therefore excited almost equally, and the voltage drop across resistor R39 caused by the signal applied to tube V14 is almost cancelled by a voltage of opposite polarity caused by the signal applied to tube V13. The remaining uncancelled voltage across resistor R39 corresponds to the unbalance between the signals applied to tubes V13 and V14. This unbalanced voltage then excites the grid of the phase-inverter section of tube V12 so that the output of the phase inverter tends to reduce the unbalance. The high-gain inverter stage provides for a very small percentage of unbalance even with some variations in the value of the circuit constants.

**b.** The voltage drop across cathode resistor R34 and bypass capacitor C41 provides bias for the grids of tube V12. Bias for the grids of tubes V13 and V14 is provided by the drop across cathode resistor R42 and bypass capacitor C47. Screen-grid voltage for tubes V13 and V14 is supplied directly from the power supply. Plate voltage for these tubes is supplied through the primary of transformer T8 from the filament of the rectifier tube. Resistor R43 and capacitor C76 in series serve to load the primary of the output transformer T8. The secondary of this transformer

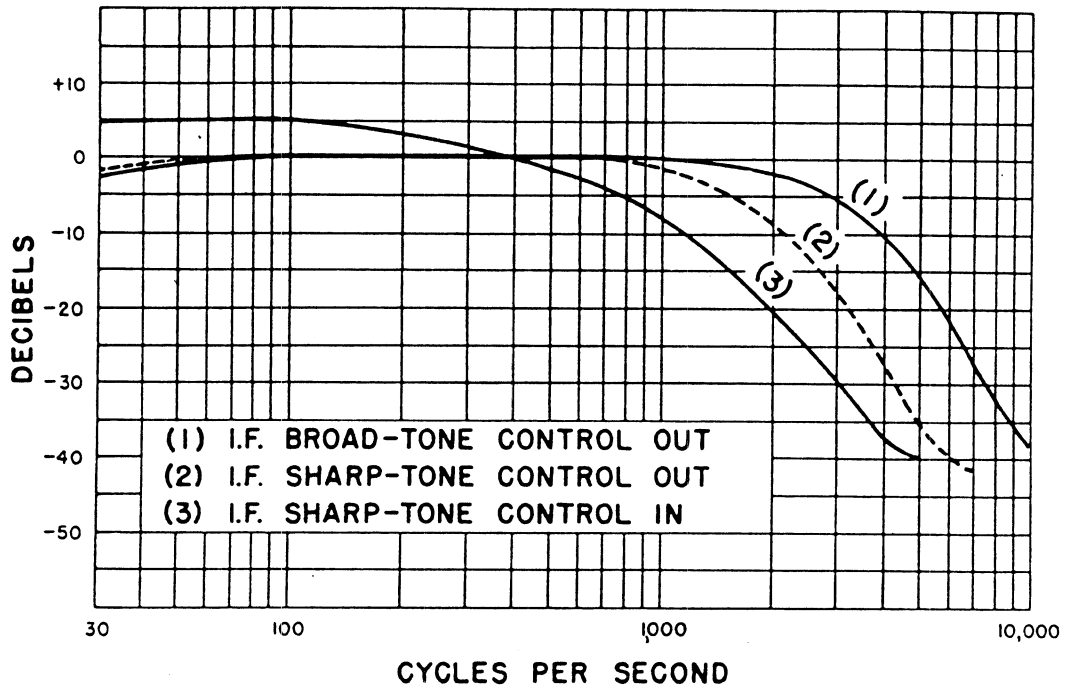

TL-14317

Figure 17. Effect of TONE control on audio fidelity at BROAD I.F. and SHARP I.F. positions of SELECTIVITY control, BASS switch at IN position.

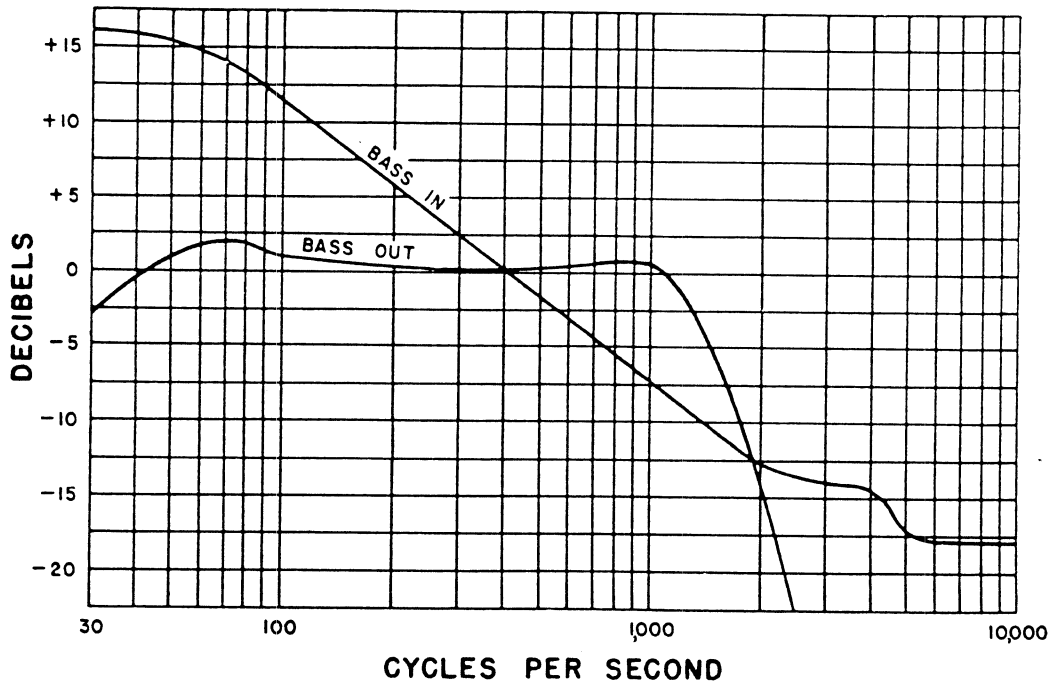

TL-14318

Figure 18. Audio frequency response with BASS switch IN and OUT, SELECTIVITY control at the XTAL SHARP position.

is tapped for three output impedances; a 500-ohm line, a 5,000-ohm speaker, or output for a headset at jack J2 on the front panel. Resistor R44 serves as a load on the transformer secondary when a headset is used.

c. The plate circuit of the first section of tube V12 contains a bass compensator and a tone control circuit. When the bass switch SW10 is in the IN position, the parallel resonant circuit consisting of choke CH2 and capacitor C43 presents a high impedance to the low-frequency a-f signals thereby providing a greater signal voltage for the succeeding stage. Attenuation of the high frequencies is provided by the circuit consisting of capacitor C42 and the tone control R35. The audio fidelity curve is shown in figure 17. The effect of the bass control upon fidelity is shown in figure 18.

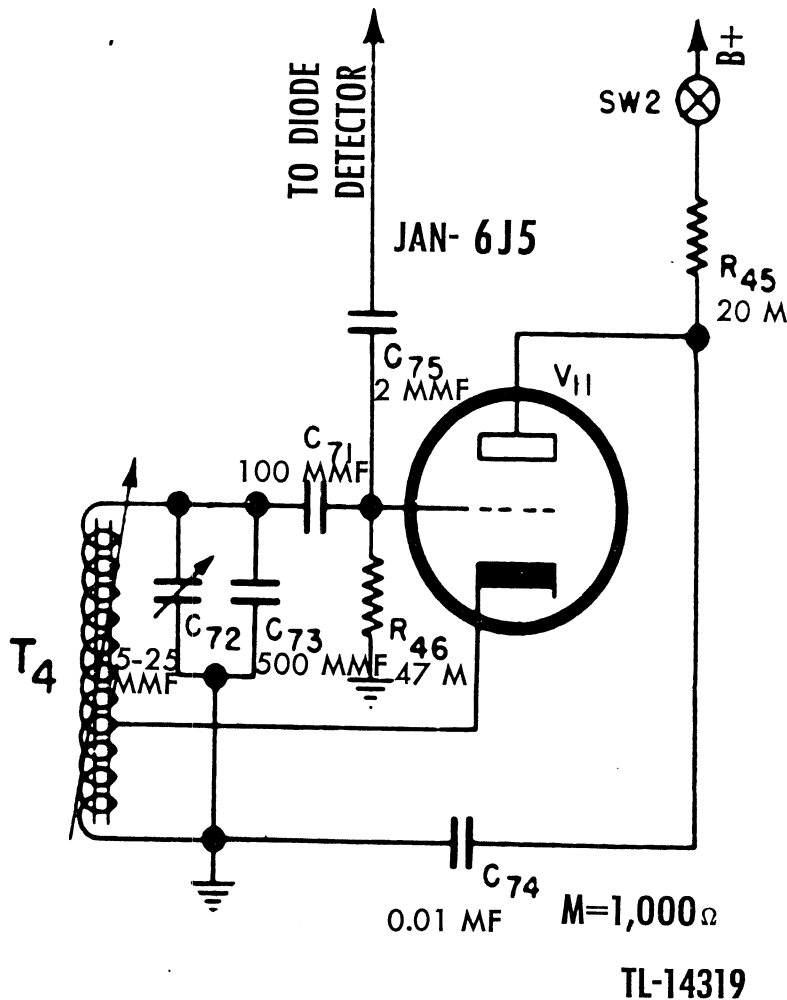
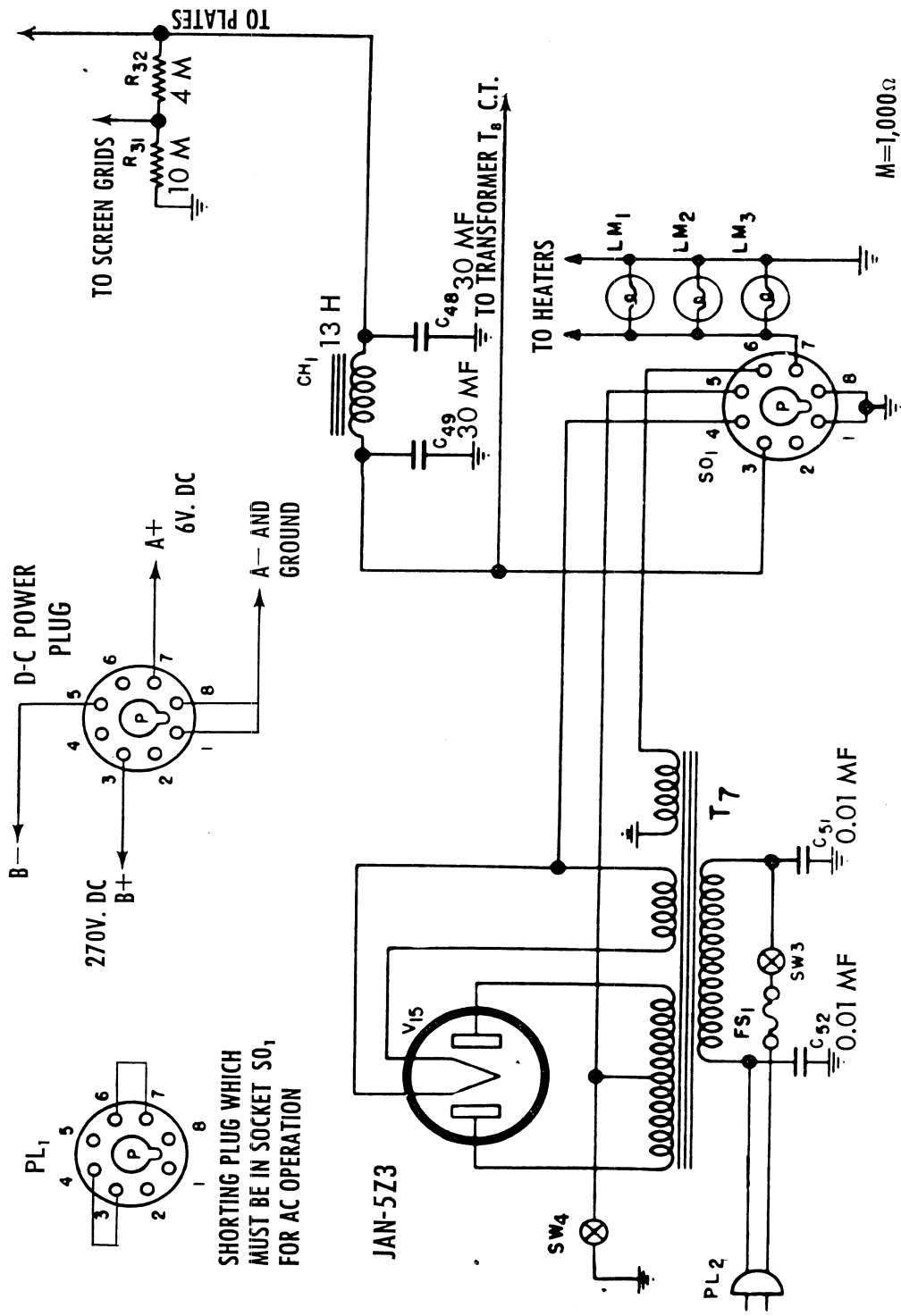

Figure 19. Beat-frequency oscillator, schematic.



TL-14320

Figure 20. Power supply, schematic.

## 20. BEAT-FREQUENCY OSCILLATOR (fig. 19).

The BFO uses Tube JAN-6J5 (V11) in a Hartley circuit, with feed back taking place between the cathode and grid sections of inductor T4. Fixed capacitor C73, shunted by variable capacitor C72, and the permeability tuned inductor T4, constitute a tuned circuit resonant to the intermediate frequency. The variable capacitor C72 is adjusted by means of the B.F.O. control on the front panel to vary the frequency of the BFO and consequently the frequency of the resultant beat note. Switch SW2 controls the operation of the BFO by supplying or interrupting the plate potential applied to the tube through dropping resistor R45. Capacitor C74 serves as a plate bypass. Bias for the tube is supplied by grid current passing through resistor R46, C71 acting as a blocking capacitor. The output of the oscillator is taken from the grid circuit of tube V11 and applied to the diode detector through capacitor C75.

## 21. POWER SUPPLY (fig. 20).

The power supply system is conventional for a-c operation with provision made for battery or pack operation. When operating from an a-c source, plug PL1 (fig. 27) is inserted in socket SO1 located on the rear apron of the chassis. For d-c operation, a plug similar to PL1 is wired with terminals leading to the points shown. The primary of the power transformer T7 is fused by fuse FS1 and bypassed to ground by capacitors C51 and C52. Switch SW3 is the main operating switch, while switch SW4 opens the high-voltage negative return lead, making the receiver inoperative. The output of full-wave rectifier Tube JAN-5Z3, V15 is filtered by choke CH1 and filter capacitors C48 and C49. Screen-grid voltage is supplied from the junction of bleeder resistors R31 and R32. Pilot lights and tube heaters, with the exception of the rectifier, use a common secondary source having one side grounded.

# SECTION IV

## MAINTENANCE

NOTE: Failure or unsatisfactory performance of equipment will be reported on W.D., A.G.O. Form No. 468. If this form is not available, see TM 38-250.

### 22. INSPECTION.

**a. General.** Radio Receiver AN/GRR-2 should be inspected at periodic intervals for indications of electrical or mechanical failure.

**b. Detailed.** (1) ELECTRICAL. (a) Inspect the rectifier Tube JAN-5Z3 (V15) for evidence of gas while the receiver is in operation. A blue glow appearing within the tube indicates the presence of gas which impairs the normal operation of the tube and makes replacement necessary.

(b) Remove the dust cover from the gang capacitor assembly and inspect gang capacitors for an accumulation of dust particles which may have collected. If necessary, blow the particles out with an air hose supplying clean, dry air.

(c) Remove the bottom chassis cover plate and inspect it for an accumulation of wax which, if present, would indicate excessive temperature of an operating component.

(d) Check antenna, ground, speaker, and power line connections making sure that the connecting terminations are clean, positioned properly so that shorts do not occur, and that they are making secure electrical contact with their respective terminals.

(e) Make sure that the dial lights are firmly seated in their sockets and operate when the receiver is turned on.

### (2) MECHANICAL.

(a) Make sure that all tubes are firmly seated in their proper sockets.

(b) Check all operating controls to make sure that they operate freely. Do not force a control which may be jammed. An inspection of the device actuated by the control will generally show the fault and suggest the remedy.

(c) Remove the bottom chassis cover plate and reposition any wire or component which may be in mechanical contact with a rotary shaft.

(d) Make sure that the dust cover over the gang capacitor assembly is held firmly in place by the four spring clips provided.

(e) Remove any accumulation of dust, moisture, or corrosion from interior components.

### 23. LUBRICATION.

It is not considered essential that shaft bearings or gears be lubricated.

### 24. REPLACEMENT.

**a. Tubes.** When tube failure is suspected, substitute tubes of known quality. Be sure that the replacement tube is identical in type with the original.

**b. Pilot Lights.** Replace pilot lights immediately on burnout with one of identical characteristics. The lights are of the bayonet-base type and are accessible on opening the top cover of the receiver.

**c. Fuses.** The operating power supply line fuse is located in a plug mounted on the rear apron of the chassis (fig. 2). The spare fuse is held in a clip mounted on top of the chassis near the power rectifier tube (fig. 8). When necessary, replace the blown operating fuse with the spare, and replace the spare fuse with one of identical characteristics.

### 25. FIELD ADJUSTMENTS.

**a.** S meter control is obtained by varying the knurled knob appearing on the left-hand rear chassis apron edge (fig. 2). This control sets the S meter to zero. In order to make the adjustment correctly, the R.F. GAIN control must be advanced clockwise as far as it will go. In addition, the AVC — BFO switch must be in the A.V.C.-ON position. When these conditions have been complied with, remove the antenna from the receiver and adjust the S meter control until the S meter reads zero (extreme left of scale). Reconnecting the antenna to the receiver will then make the meter indicate the relative carrier strength of each incoming signal as the signal is tuned in.

**b.** If a control knob slips on its shaft or a coupling loosens, the setscrews provided should be tightened with a screwdriver making sure that the screw engages a flatted surface, if provided, on the shaft.

**c.** If a clip contacting the top cap of a tube becomes loose, pinch slightly with a pair of pliers until the clip fits tightly over the top cap.

### 26. TROUBLE LOCATION CHART.

Symptom	Possible cause	Remedy
1. No signals	1a. SEND-RECEIVE switch at SEND. b. Power line dead. c. Defective operating switch. d. Grounded antenna.	1a. Set switch at RECEIVE. b. Plug receiver into live line. c. Repair or replace switch. d. Repair or reposition shorting portion.

Symptom	Possible cause	Remedy
2. Weak signals	<i>e.</i> Defective tube.	<i>e.</i> Replace with identical tube.
	<i>f.</i> Defective speaker.	<i>f.</i> Repair or replace speaker.
	<i>g.</i> Defective circuit.	<i>g.</i> Check by continuity and repair or replace defective component.
3. Poor quality	2 <i>a.</i> Weak tube or tubes.	2 <i>a.</i> Test tubes, replacing those not testing within acceptable limits.
	<i>b.</i> Poor antenna pickup.	<i>b.</i> Reposition antenna so that it is well above surrounding objects and in a clear space. Check insulators.
	<i>c.</i> Circuits out of alignment.	<i>c.</i> Align receiver circuits according to procedure outlined in paragraph 29.
	<i>d.</i> Defective circuit component.	<i>d.</i> Check circuit by continuity and repair or replace defective component.
	<i>e.</i> Signal not tuned in properly.	<i>e.</i> Adjust tuning controls for proper resonance.
4. Noisy or intermittent reception	3 <i>a.</i> Selectivity control at wrong position.	3 <i>a.</i> Set SELECTIVITY control at BROAD I.F. or MEDIUM I.F.
	<i>b.</i> Defective tube.	<i>b.</i> Test and replace tube or tubes.
	<i>c.</i> Bass control at wrong position.	<i>c.</i> Set BASS control at IN.
	<i>d.</i> Receiver circuits out of alignment.	<i>d.</i> Align receiver according to procedure outlined in paragraph 29.
	<i>e.</i> Defective speaker.	<i>e.</i> Repair or replace speaker.
	<i>f.</i> Defective circuit component.	<i>f.</i> Check circuit continuity and repair or replace defective component.
4. Noisy or intermittent reception	4 <i>a.</i> Loose element in tube.	4 <i>a.</i> Test tubes particularly for noise and replace if defective.
	<i>b.</i> Intermittent antenna ground.	<i>b.</i> Position antenna and lead-in so that they are free of obstructions which may be grounded.
	<i>c.</i> Broken speaker leads.	<i>c.</i> Repair or replace leads.
	<i>d.</i> Defective receiver component.	<i>d.</i> Check circuit continuity and repair or replace defective component.

## 27. VOLTAGE READINGS.

The voltage readings listed in figure 21 were obtained through the use of an RCA Voltohmyst Junior under the following conditions, unless otherwise noted. Voltages are dc unless otherwise indicated.

- a. A.F. GAIN control at position No. 9.
- b. R.F. GAIN control at position No. 9.
- c. TONE control at position No. 9.
- d. BANDSWITCH 3 to 5.8 megacycles.
- e. A.V.C. control ON except as noted.
- f. A.N.L. control OFF except as noted.
- g. SEND-RECEIVE switch at RECEIVE.
- h. SELECTIVITY control at BROAD I.F.
- i. All controls not mentioned set at random.
- j. A 5,000-ohm resistor was placed across the speaker terminals while voltage readings were being taken.
- k. Line voltage for test 110 volts, 60 cycles ac.

**NOTE:** The tube pins of tubes V1 first r-f, V2 second r-f, V3 mixer, and V4 h-f oscillator are not accessible from the bottom of the chassis. Voltages were obtained for these tubes by removing each of these tubes in succession from their respective sockets and measuring the voltage from the top socket pin position. All other tubes were in position while the readings were being made.

## 28. RESISTANCE MEASUREMENTS.

The ohmmeter readings indicated in the following table were made from the top of the chassis with all tubes removed and controls set as indicated below. All readings unless otherwise specified are made to the chassis, which is considered ground. The instrument used for obtaining the readings was an RCA Voltohmyst Junior.

- a. A-C line switch ON with TONE control at position No. 9.
- b. A.F. GAIN control at position No. 9.
- c. R.F. GAIN control at position No. 9.
- d. BANDSWITCH 3 to 5.8 MC band.
- e. A.V.C. control ON except as noted.
- f. A.N.L. control OFF except as noted.
- g. SEND-RECEIVE switch at RECEIVE.
- h. SELECTIVITY control at BROAD I.F.
- i. Antenna, ground, power cord, and speaker disconnected.

**NOTE:** Component numbers (R and C) refer to markings on figure 27. DL is the abbreviation for dead lug; TC for top cap.



Tube	Pin	Normal resistance (ohms)	Above normal reading caused by	Below normal reading caused by
V1 JAN-6AB7 1st r-f amplifier	1	0		
	2	0		
	3	350	R2,R3 open.	C14 shorted.
	4	0.9 meg	R1,R58,R59,R60, R61,R74 open. SW8-1,SW8-4,SW8-3,  SW8-15 defective.	Grounded capacitors on SW8-4. Grounded antenna coil assembly C6, C17,C65,C66,C64, C77.
	5	350	R2,R3 open.	C14 shorted.
	6	44,000	R4,R31,R32 open.	C15,C16,C19,C20, C23,C24,C27,C28, C35,C36,C40,C42, C44,C46,C45,C48, C49,C56,C57,C62, C67,C70,C86 shorted.
	7	0.1 ohm		Shorted transformer winding.
	8	15,000	R5,R31,R32 open. R-f plate coil assembly open. SW8-5 defective.	C15,C16,C19,C20, C23,C24,C27,C28, C35,C36,C40,C42, C44,C45,C46,C48, C49,C56,C57,C62, C67,C70,C86 shorted.
V2 JAN-6SK7 2d r-f amplifier	1	0		
	2	0		
	3	350	R2,R8 open.	C18 shorted.
	4	0.9 meg	R7,R58,R59,R60, R61 open. SW8-6,SW8-15 defective. Grid coil assembly defective.	Grounded capacitors on SW8-7. Defective grid coil assembly. C17,C64,C65,C66, C77 shorted.
	5	350	R2,R8 open.	C18 shorted.
	6	12,000	R9,R31 open.	C15,C16,C19,C20, C23,C24,C27,C28, C35,C36,C40,C42, C44,C45,C46,C48, C49,C56,C57,C62, C67,C70,C86 shorted.
	7	0.1		Shorted transformer winding.
	8	18,000	R10,R31,R32 open. R-f plate coil assembly open. SW8-8 defective.	C15,C16,C19,C20, C23,C24,C27,C28, C35,C36,C40,C42, C44,C45,C46,C48, C49,C56,C57,C62, C67,C70,C86 shorted.

Tube	Pin	Normal resistance (ohms)	Above normal reading caused by	Below normal reading caused by
V3 JAN-6SA7 Mixer	1	0		
	2	0		
	3	18,000	Primary T1 open. R14,R31,R32 open.	C15,C16,C19,C20, C23,C24,C27,C28, C35,C36,C40,C42, C44,C45,C46,C48, C49,C56,C57,C62, C67,C70,C86 shorted.
	4	12,000	R13,R31 open.	C15,C16,C19,C20, C23,C24,C27,C28, C35,C36,C40,C42, C44,C45,C46,C48, C49,C56,C57,C62, C67,C70,C86 shorted.
	5	55,000	R65 open.	C68 short.
	6	400	R12 open.	C22 shorted.
	7	0.1		Shorted transformer winding.
	8	0.9 meg	R11,R58,R59,R64 open. SW8-9,SW8-10 defective. Grid coil assembly defective.	Grounded capacitors on SW8-10. Defective grid coil assembly. C21,C64,C65,C66 shorted.
V4 JAN-6SA7 H-f osc	1	0		
	2	0		
	3	29,000	R6,R31,R32,R47, R71 open. Osc plate coil open.	C15,C16,C19,C20, C23,C24,C27,C28, C35,C36,C40,C42, C44,C45,C46,C48, C49,C56,C57,C62, C67,C70,C86 shorted.
	4	29,000	R6,R31,R32,R47, R71 open.	C15,C16,C19,C20, C23,C24,C27,C28, C35,C36,C40,C42, C44,C45,C46,C48, C49,C56,C57,C62, C67,C70,C86 shorted.
	5	56,000	R66 open.	C69 shorted.
	6	0	Defective SW11. Defective osc coil assembly.	
	7	0.1		Shorted transformer windings.
	8	29,000	R6,R31,R32,R47, R71 open. Osc plate coil open.	C15,C16,C19,C20, C23,C24,C27,C28, C35,C36,C40,C42, C44,C45,C46,C48, C49,C56,C57,C62, C67,C70,C86 shorted.

Tube	Pin	Normal resistance (ohms)	Above normal reading caused by	Below normal reading caused by
V5 JAN-6L7 1st i-f amplifier	1	0		
	2	0		
	3	18,000	Primary T2 open. R18,R31,R32 open. Defective SW9-2.	C15,C16,C19,C20, C23,C24,C27,C28, C35,C36,C40,C42, C44,C45,C46,C48, C49,C56,C57,C62, C67,C70,C86 shorted.
	4	12,000	R17,R31 open.	C15,C16,C19,C20, C23,C24,C27,C28, C35,C36,C40,C42, C44,C45,C46,C48, C49,C56,C57,C62, C67,C70,C86 shorted.
	5 6DL	0.9 meg 30,000	R49 open.	C55 shorted.
	7	0.1		Shorted transformer winding. C26 shorted.
	8	1,500	R2,R16,R26,R68 open. Defective SW8-14.	
	TC	1.15 meg	R15,R25,R27 open. Secondary T1 open. Defective SW9-1.	Defective SW9-1. C25,C37,C39 shorted.
V6 JAN-6SK7 2d i-f amplifier	1	0		
	2	0		
	3	350	R2,R21 open.	C34 open.
	4	100,000	R19,R20 open.	C33 shorted. Defective SW9-3. Defective crystal assem.
	5	350	R2,R21 open.	C34 open.
	6	12,000	R22,R31 open.	C15,C16,C19,C20, C23,C24,C27,C28, C35,C36,C40,C42, C44,C45,C46,C48, C49,C56,C57,C62, C67,C70,C86 shorted.
	7	0.1		Shorted transformer winding.
	8	18,000	R23,R31,R32 open. Primary T3 open.	C15,C16,C19,C20, C23,C24,C27,C28, C35,C36,C40,C24, C44,C45,C46,C48, C49,C56,C57,C62, C67,C70,C86 shorted.

Tube	Pin	Normal resistance (ohms)	Above normal reading caused by	Below normal reading caused by
V7 JAN-6B8 Detector, S meter tube	1	0		
	2	0		
	3	47,000	R28,R30,R31,R32 open.	C15,C16,C19,C20, C23,C24,C27,C28, C35,C36,C40,C42, C44,C45,C46,C48, C49,C56,C57,C62, C67,C70,C86 shorted.
	4	450,000	Secondary T3 open. R24,R25 open.	C25,C37,C39,C53 shorted.
	5	450,000	Secondary T3 open. R24,R25 open.	C25,C37,C39,C53 shorted.
	6	10,000	R31 open.	C15,C16,C19,C20, C23,C24,C27,C28, C35,C36,C40,C42, C44,C45,C46,C48, C49,C56,C57,C62, C67,C70,C86 shorted.
	7	0.1		Shorted transformer winding.
	8	0		
V12 JAN-6SC7 1st audio amplifier	1	0		
	2	160,000	R31,R32,R37,R38 open. CH2 open.	C15,C16,C19,C20, C23,C24,C27,C28, C35,C36,C40,C42, C44,C45,C46,C48, C49,C56,C57,C62, C67,C70,C86 shorted.
	3	550,000	A.F. GAIN control open.	Shorted A.F. GAIN control. Shorted Phono switch.
	4	200,000	R39 open.	C15,C16,C19,C20, C23,C24,C27,C28, C35,C36,C40,C42, C44,C45,C46,C48, C49,C56,C57,C62, C67,C70,C86 shorted.
	5	165,000	R31,R32,R36,R38 open.	C15,C16,C19,C20, C23,C24,C27,C28, C35,C36,C40,C42, C44,C45,C46,C48, C49,C56,C57,C62, C67,C70,C86 shorted.
	6	1,000	R34 open.	C41 short.
	7	0.1		Shorted transformer winding.
	8	0		

Tube	Pin	Normal resistance (ohms)	Above normal reading caused by	Below normal reading caused by
V13 and V14 JAN-6V6GT PP Audio	1	0		
	2	0		
	3	15,000	R31,R32 open. Primary T8 open. CH1 open.	C15,C16,C19 C20, C23,C24,C27,C28, C35,C36,C40,C42, C44,C45,C46,C48, C49,C56,C57,C62, C67,C70,C86 shorted.
	4	15,000	R31,R32 open.	C15,C16,C19,C20, C23,C24,C27,C28, C35,C36,C40,C42, C44,C45,C46,C48, C49,C56,C57,C62, C67,C70,C86 shorted.
	5	500,000	R40,R39,R41 open.	
	6DL	70,000		
	7	0.1		Shorted transformer winding.
	8 3 to 3 5 to 5	250 500 600,000	R42 open. T8 Pri. open. R40,R41 open.	C47 shorted. C76 shorted.
V11 JAN-6J5 B.F.O. B.F.O. switch at ON	1	0		
	2	0		
	3	37,000	R31,R32,R45 open. SW2 defective.	C15,C16,C19,C20, C23,C24,C27,C28, C35,C36,C40,C42, C44,C45,C46,C48, C49,C56,C57,C62, C67,C70,C86 shorted.
	4DL	37,000		
	5	60,000	R46 open.	C71 shorted.
	6DL			
7	0.1		Shorted transformer winding.	
8	0	Open T4.		
V10 JAN-6H6 noise rectifier. A.N.L. control at No. 9	1	0		
	2	0		
	3	1 meg	R49 open. Secondary No. 5 open.	C55 shorted.
	4	150,000	R48,R53 open.	C54 shorted.
	5	1.5 meg	R24,R25,R70 open.	C37,C53 shorted.
	6DL	40,000		
	7	0.1		Transformer winding shorted.
8	400,000	R25 open. SW5-1 defective.		

Tube	Pin	Normal resistance (ohms)	Above normal reading caused by	Below normal reading caused by
V8 JAN-6B8 a-v-c amplifier	1	0		
	2	0		
	3	18,000	R31,R32,R63 open. Primary T6 open.	C15,C16,C19,C20, C23,C24,C27,C28, C35,C36,C40,C42, C44,C45,C46,C48, C49,C56,C57,C62, C67,C70,C86 shorted.
	4	400,000	R58,R59,R60 open. Secondary T6 open.	C64,C65,C66 shorted.
	5	400,000	R58,R59,R60 open. Secondary T6 open.	C64,C65,C66 shorted.
	6	10,000	R31,R56 open.	C15,C16,C19,C20, C23,C24,C27,C28, C35,C36,C40,C42, C44,C45,C46,C48, C49,C56,C57,C62, C67,C70,C86 shorted.
	7	0.1		Transformer winding shorted.
	8 TC	200 500,000	R58 open. R62 open.	C63 shorted.
V9 JAN-6AB7 noise amplifier. A.N.L. control at No. 9	1	0		
	2	0		
	3	450	R53,R54 open. SW5 defective.	C54,C58 shorted.
	4	1.2 meg	R55,R57,R58,R59, R64 open.	C59,C65 shorted.
	5	450	R53,R54 open. SW5 defective.	C54,C58 shorted.
	6	34,000	R31,R32,R51 open.	C15,C16,C19,C20, C23,C24,C27,C28, C35,C36,C40,C42, C44,C45,C46,C48, C49,C56,C57,C62, C67,C70,C86 shorted.
	7	0.1		Transformer winding shorted.
	8	15,000	R31,R32,R50 open. Primary T5 open.	
V15 JAN-5Z3 Rectifier	F1 or F2	15,000	R31,R32 open. Open in operating plug. SO1,CH1 open.	C15,C16,C19,C20, C23,C24,C27,C28, C35,C36,C40,C42, C44,C45,C46,C48, C49,C56,C57,C62, C67,C70,C86 shorted.
	F1 to F2	0.1	Transformer secondary open.	Shorted transformer secondary.

Tube	Pin	Normal resistance (ohms)	Above normal reading caused by	Below normal reading caused by
V15 JAN-5Z3 Rectifier	P1 to G	40	High-voltage secondary open. Defective SW4.	Shorted high-voltage secondary.
	P2 to G	38	High-voltage secondary open.	Shorted high-voltage secondary.
	P1 to P2	78	High-voltage secondary open.	Shorted high-voltage secondary.

## 29. ALIGNMENT PROCEDURE.

**a. Equipment.** The following equipment is necessary for alignment:

- (1) A modulated all-wave signal generator which will provide an accurately calibrated signal from 450 kc to 43 mc.
- (2) An output indicating meter connected to 5,000-ohm output terminals.
- (3) A non-metallic screwdriver.
- (4) A dummy antenna consisting of a 400-ohm carbon resistor.
- (5) A high-resistance type voltmeter such as Test Unit I-176, a component of Test Set I-56-K.

### **b. Control Positions (fig. 3).**

- (1) TONE control at maximum high frequency position (No. 9).
- (2) B.F.O. control at zero.
- (3) BASS switch at IN.
- (4) A.F. GAIN control at maximum (No. 9).
- (5) BANDSWITCH for i-f alignment .55- to 1.6-megacycle band.
- (6) BANDSWITCH for r-f alignment set at band being aligned.
- (7) SELECTIVITY control at SHARP I.F.
- (8) SEND-RECEIVE switch at RECEIVE.
- (9) CRYSTAL PHASING control at No. 11½ on left side.
- (10) A.N.L. control at OFF (zero).
- (11) A.V.C. control at A.V.C.-OFF.
- (12) BANDSPREAD control at 100 on the logging scale.
- (13) ANTENNA TRIMMER must be adjusted for maximum gain at each r-f alignment point.
- (14) R.F. GAIN control at maximum (No. 9).

### **c. I-f Alignment 455 Kc (fig. 22).**

- (1) Set main dial at 1,400 kc on .55- to 1.6-mc band.
- (2) Connect the hot lead from the signal generator to the mixer Tube JAN-6SA7 (V3) terminal No. 8. Connect the ground of the signal generator to the chassis. Adjust the signal generator to produce a 455-kc modulated signal.

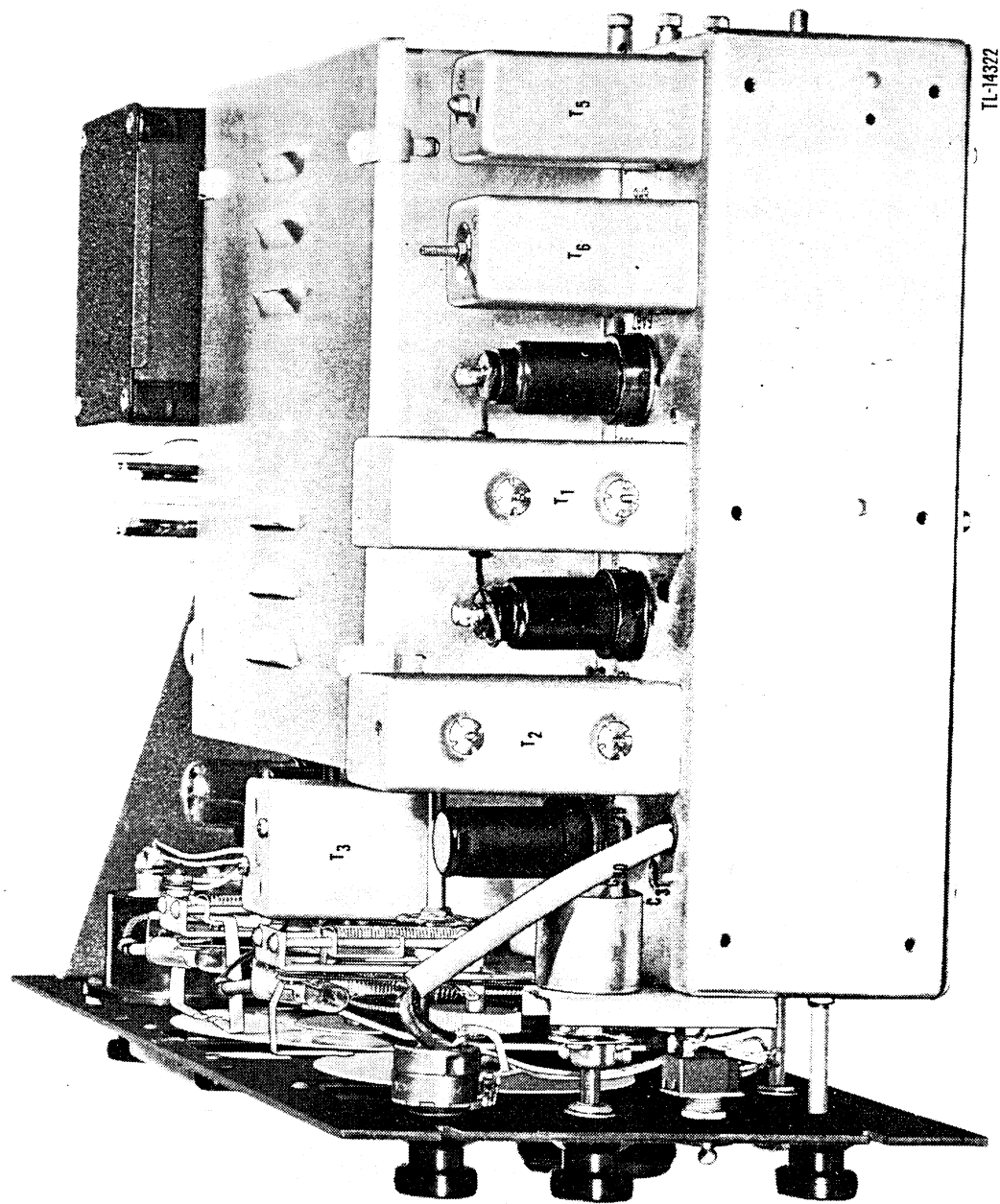

*Figure 22. I-f aligning adjustments.*

**NOTE:** Adjust the output of the signal generator so that only enough signal is supplied to cause reasonable deflections on the output meter. Use that voltage range on the output meter which best indicates small variations in output from the receiver. If the indicator goes off scale as alignment progresses, reduce the output from the signal generator.

(3) For maximum reading of the output meter, roughly adjust the aligning screws of transformer T1 (fig. 22). The lower screw is accessible through the hole in right mounting bracket.

(4) Adjust the alignment screw on transformer T2 for maximum output meter reading.

(5) Adjust capacitor C31 (figs. 8 and 22) and the air trimmer capacitors at the top of transformer T3 (fig. 22) for maximum output.

(6) Switch to CRYSTAL BROAD position.

**NOTE:** The signal generator should produce an unmodulated signal for adjusting the three crystal positions.

(7) Turn on the B.F.O. and adjust to a tone of about 1000 cycles.

(8) Vary the frequency of the signal generator about the 455-kc setting while adjusting the top screw on transformer T2 (fig. 22) until the output goes through a maximum, dips down, and rises to another maximum.

(9) Adjust the phasing control for maximum selectivity and back off the top screw on transformer T2 until the output reaches a minimum value between the two maximum values first noted.

**NOTE:** The frequency of the signal generator should be varied over a small range while adjusting the top screw of transformer T2.

A swishing note, in contrast to the usual sharp crystal tone will be heard when the correct adjustment has been made.

(10) Switch to XTAL SHARP and adjust capacitor C30 (figs. 8 and 22) for maximum output while varying the signal generator frequency. Two points of maximum output will be noted corresponding to two adjustments of C30. Either one of these points may be used for the setting of C30. A sharply peaked tone will result with the correct adjustment.

(11) Switch to XTAL MEDIUM and adjust C29 till the output is midway between the outputs reached while aligning the XTAL SHARP and XTAL BROAD positions. The apparent sharpness of tone should be midway between the "sharp" and "broad" positions.

(12) Switch again to XTAL SHARP and set the signal generator to the exact crystal frequency.

(13) Turn off the B.F.O.

(14) Switch again to SHARP I.F. and carefully realign the i-f transformers as described in subparagraphs (3) to (5) above.

**CAUTION:** Do not adjust the top adjustment screw of transformer T2.

**d. B.F.O. Adjustment.**

- (1) Set the front panel control to zero.
- (2) Turn the B.F.O. switch ON.
- (3) Leave the signal generator set at the crystal frequency and turn off the modulation.
- (4) Set the selectivity switch at I.F. SHARP position.
- (5) After loosening locknut, adjust the screw on top of transformer T4 to zero beat (fig. 8).

**e. A.N.L. and A.V.C. Amplifier Adjustments.**

(1) A.N.L. ALIGNMENT.

(a) With all controls set as for i-f alignment, turn the A.N.L. control all the way to the right.

(b) Connect the signal generator to the grid (pin No. 4) of Tube JAN-6AB7 (V9).

(c) Connect a high-resistance type d-c voltmeter across resistor R49 (fig. 27) which is connected between the grid (pin No. 5) of the i-f amplifier Tube JAN-6L7 (V5) and the chassis.

(d) Connect a 50,000-ohm carbon resistor across the primary winding of transformer T5 (fig. 27) (red and blue leads).

(e) Set the signal generator at the i-f frequency and turn up its output to approximately 100,000 microvolts.

(f) Adjust trimmer capacitors C110 and C111 of transformer T5 for the maximum d-c voltmeter reading.

(g) Disconnect the d-c voltmeter and 50,000-ohm resistor connected across the primary of transformer T5.

(h) Connect the signal generator to the grid (pin No. 8) of the mixer Tube JAN-6SA7 (V3), and remove the grid cap of the i-f amplifier Tube JAN-6L7 (V5).

(i) With the signal generator set at the i-f frequency and with the modulation turned on, adjust the wave trap trimmer capacitor C55 for the null point or minimum output as indicated on the audio output meter.

(j) Reconnect the grid cap of tube V5 and set the A.N.L. control at OFF. (Turn control all the way to the left until switch actuates.)

(2) A.V.C. ALIGNMENT.

(a) Leave the signal generator connected to the mixer tube V3 grid (pin No. 6).

(b) Set AVC — BFO switch at A.V.C.-ON.

(c) Connect the high-resistance d-c voltmeter across the tube V8 diode filter capacitor C64 (fig. 27).

(d) With the signal generator output turned up to approximately 100,000 microvolts, set the adjustment screw on transformer T6 for maximum d-c voltmeter reading.

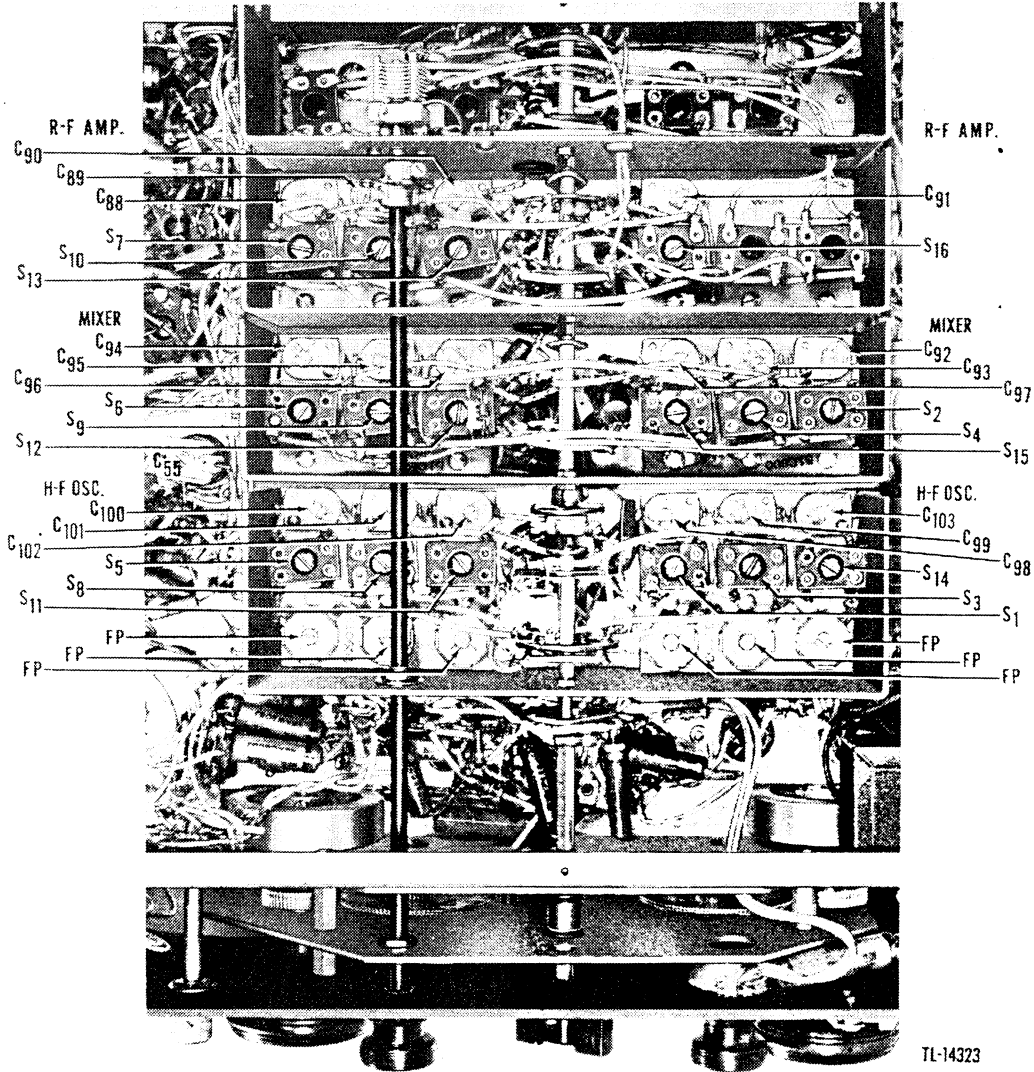

Figure 23. R-f and oscillator adjustments.

**f. R-f and Oscillator Alignment.**

(1) With all controls set for i-f alignment, connect the hot lead of the signal generator to A1 (fig. 2) through a 400-ohm dummy antenna.

(2) Connect ground lead of signal generator to G. Leave jumper connected between A2 and G.

**CAUTION:** FP, shown in figure 23, indicates a fixed pad.

Do not make any adjustments.

(3) Adjust the various controls as shown in the following table for maximum indication of the output meter. See figure 23 for these adjusting locations.

Band	Rec dial setting (mc)	Sig gen freq (mc)	Dummy antenna (ohms)	High-frequency end		Low-frequency end	
				Adjust osc capacitor	Adjust trimmer capacitor	Adjust osc slug	Adjust r-f slugs
1	1.5	1.5	400	C98	C92	..	.....
1	0.6	0.6	400	....	.....	S1	S2
2	3.0	3.0	400	C99	C93	..	.....
2	1.8	1.8	400	....	.....	S3	S4
3	5.4	5.4	400	C100	C94 C88	..	.....
3	3.0	3.0	400	....	.....	S5	S6 S7
4	10.0	10.0	400	C101	C95 C89	...	.....
4	7.0	7.0	400	....	.....	S8	S9 S10
5	20.0	20.0	400	C102	C96 C90	....	.....
5	12.0	12.0	400	....	.....	S11	S12 S13
6	36.0	36.0	400	C103	C97 C91	....	.....
6	24.0	24.0	400	....	.....	S14	S15 S16

### 30. PERFORMANCE SPECIFICATIONS.

#### a. Setting of Controls During Tests.

(1) R.F. GAIN control, A.F. GAIN control, TONE control, PHASING control, and A.N.L. control set to give maximum output.

(2) SELECTIVITY switch in SHARP I.F. position.

(3) A.V.C.-B.F.O. switch at A.V.C.-OFF position.

**b. I-f Sensitivity.** With an i-f input to the grid of Tube JAN-6SA7 (V3) mixer of not over 90 microvolts nor less than 45 microvolts, the output is 500 milliwatts.

**c. R-f Sensitivity.** R-f sensitivity for 500 mw output is as follows: (A dummy antenna of 400 ohms to be used throughout.)

Frequency	600 kc	1000 kc	1500 kc	1.8 mc	2.4 mc	2.8 mc	3 mc
Sensitivity	20 uv	20 uv	20 uv	10 uv	12 uv	8 uv	8 uv
Frequency	3 mc	4.2 mc	5.4 mc	7 mc	9 mc	11 mc	
Sensitivity	6 uv	6 uv	10 uv	6 uv	6 uv	8 uv	
Frequency	12 mc	14 mc	20 mc	24 mc	30 mc	36 mc	
Sensitivity	14 uv	11 uv	11 uv	15 uv	12 uv	20 uv	

**d. Frequency Calibration.** (1) **MAIN TUNING SCALE.** At check points, calibration is within five divisions on logging scale (skirt of control knob). Between check points, calibration is within ten divisions on logging scale, except on No. 6 band, from 37 mc to 42 mc, where calibration is within 22 divisions on logging scale.

(2) **BANDSPREAD SCALE.**

10-meter band within 1 division.

20-meter band within  $\frac{1}{2}$  division.

40-meter band within  $\frac{1}{2}$  division.

80-meter band within  $\frac{1}{2}$  division.

(3) **BANDSPREAD LOCATION.** Bandspread location is to be within  $\frac{1}{32}$ -inch from the center of the band-locating circle on the main tuning dial.

**e. Backlash.** Backlash is within  $\frac{1}{2}$  division on the bandspread logging scale, and within 2 divisions on the main tuning hand-wheel scale.

**f. Selectivity.** I-f selectivity measured at the grid of the 6SA7 mixer tube in I.F. SHARP position is 25 kc or less at 60 db down from resonance.

**g. Image Ratio.**

(1) Better than 6,000 times when measured at 1,000 kc on band No. 1.

(2) Better than 550 times when measured at 2.4 mc on band No. 2.

(3) Better than 7,500 times when measured at 4.0 mc on band No. 3.

(4) Better than 600 times when measured at 9.0 mc on band No. 4.

(5) Better than 350 times when measured at 14.0 mc on band No. 5.

(6) Better than 40 times when measured at 30.0 mc on band No. 6.

**h. Play in Controls.** The maximum play measured in a direction perpendicular to the panel is not to be over  $\frac{1}{32}$ -inch.

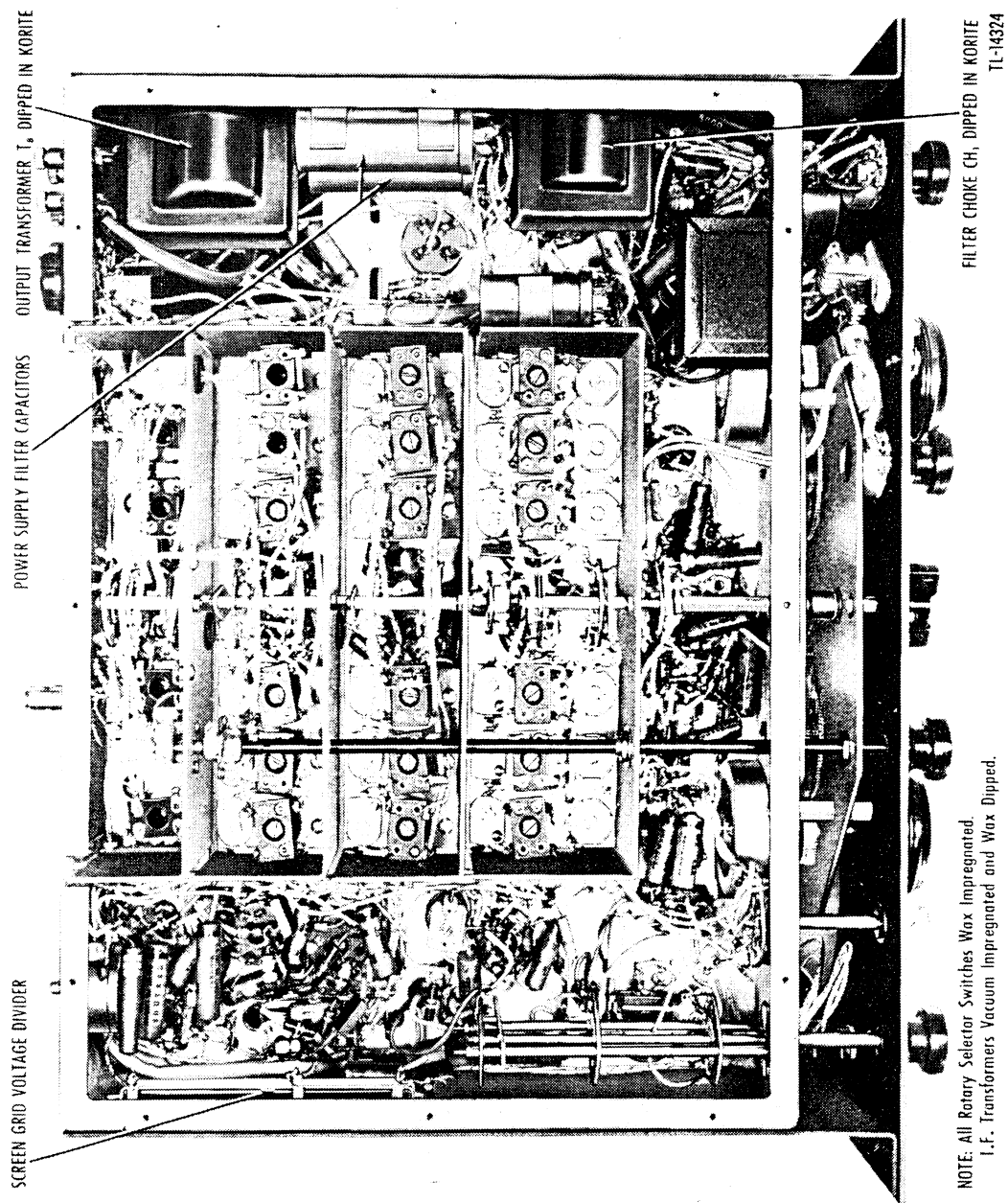
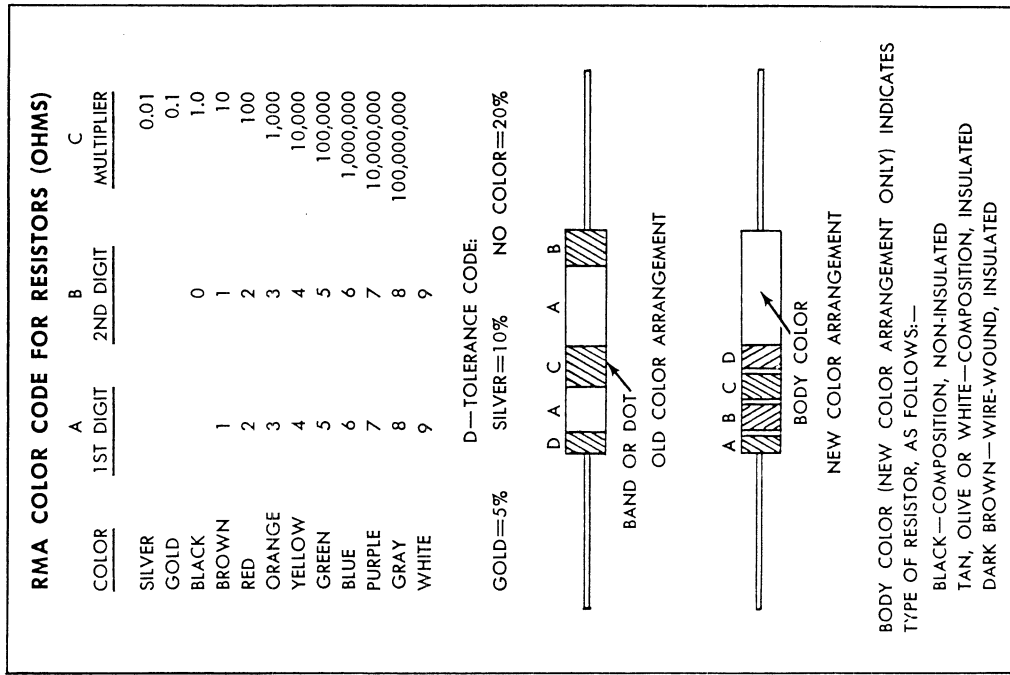

Figure 24. Radio Receiver AN/GRR-2, bottom view.



TL-14326

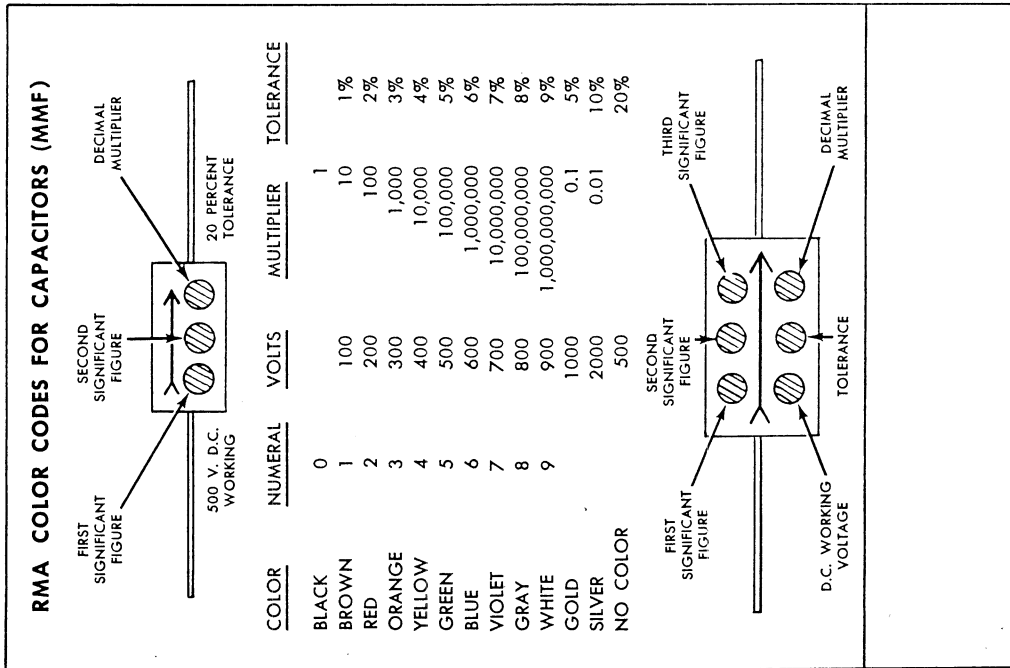

Figure 25. Color code chart.

### 31. MOISTUREPROOFING AND FUNGIPROOFING.

**α. General.** The operation of Signal Corps equipment in tropical areas where temperature and relative humidity are extremely high requires special attention. The following items represent problems which may be encountered in operation:

- (1) Resistors, capacitors, coils, chokes, transformer windings, etc., fail.
- (2) Electrolytic action takes place in resistors, coils, chokes, transformer windings, etc., causing eventual break-down.
- (3) Hook-up wire and cable insulation break down. Fungus growth accelerates deterioration.
- (4) Moisture forms electrical leakage paths on terminal boards and insulating strips, causing flash-overs.

**b. Treatment.** A moistureproofing and fungiproofing treatment has been devised which, if properly applied, provides a reasonable degree of protection against fungus growth, insects, corrosion, salt spray, and moisture. The treatment involves the use of a moisture- and fungi-resistant varnish applied with a spray gun or brush. Refer to TB SIG 13, Moistureproofing and Fungiproofing Signal Corps Equipment, for a detailed description of the varnish-spray method of moistureproofing and fungiproofing and the supplies and equipment required in this treatment.

**CAUTION:** Varnish spray may have toxic effects if inhaled. To avoid inhaling spray, use respirator if available; otherwise, fasten cheesecloth or other cloth over nose and mouth.

#### **c. Step-by-step Instructions for Treating Radio Receiver AN/GRR-2.**

(1) PREPARATION. Make all repairs and adjustments necessary for proper operation of the equipment.

(2) DISASSEMBLY.

(a) Remove eight mounting screws from edges of panel (four at each end).

(b) Disconnect leads from antenna, ground, and speaker terminals on rear chassis apron.

(c) Remove S meter control knob on left-hand edge of rear chassis apron.

(d) Remove panel and chassis from case.

(e) Remove bottom chassis cover plate by taking out the 12 mounting screws.

(f) Remove the dust cover from the gang capacitor assembly by first loosening the four spring clips holding it in place.

(g) Remove spare fuse from clip on top of chassis.

(h) Remove the following knobs from front of panel: tone control knob, BFO control knob, AF gain control knob, RF gain

control knob, band selector switch knob, antenna trimmer knob, selectivity switch knob, crystal phasing knob, A.N.L. control knob, and the band spread handwheel.

(i) Clean all dirt, rust, dust, fungus, oil, grease, etc., from the unit. Remove rust or corrosion with fine sandpaper or by scraping. Use dry-cleaning solvent, Federal Specification No. P-S-661a to remove grease or oil. A blower or compressed air hose, if available, is useful for removing dust and loose dirt.

### (3) MASKING.

(a) Mask glass in faces of S meter, main tuning dial, and band spread dial.

(b) Completely mask main tuning handwheel, including micrometer scale and locking clutch. Paper may be molded around this unit and held in place by masking tape.

(c) Place masking tape over two toggle switches (SEND-RECEIVE and BASS, IN-OUT).

(d) Cover AVC ON-OFF switch with masking tape.

(e) Cover phone jack with masking tape, and completely mask portion of phone jack on back of panel.

(f) For the 10 knobs removed from the front panel in subparagraph *b(2)(h)* above, place masking tape around each of the shafts to cover openings in panel.

(g) Completely mask main tuning and band spread gear mechanism. Mold paper around these parts and hold paper in place with masking tape.

(h) Completely mask main tuning gang capacitor assembly and band spread gang capacitor assembly. Paper should be molded around these parts, and held in place with masking tape.

(i) Mask the top of the three tube sockets from which rectifier Tube JAN-5Z3 and two power amplifier Tubes JAN-6V6/GT have been removed. Mask the bottom of all tube sockets.

(j) Mask openings for aligning screws in transformer shields as follows:

1. First i-f transformer (T1), mask two aligning screws on side of shield.
2. Second i-f transformer and crystal network (T2), mask aligning screw on side of shield.
3. Diode i-f transformer (T3), mask two aligning screws on top of shield.
4. BFO transformer (T4), mask aligning screw on top of shield.
5. ANL amplifier transformer (T5), mask two aligning screws on top of shield.

6. AVC amplifier transformer (T6), mask aligning screw on top of shield.
- (k) Mask three holes in right front corner of chassis for adjusting variable ceramic capacitors C29, C30, and C31.
- (l) Mask two pilot lamps and lamp sockets (illuminating main tuning dial and bandspread dial).
- (m) Place masking tape around S meter pilot lamp holder where it fits into back of meter case.
- (n) On rear chassis apron, mask as follows:
1. Cover three antenna-ground terminals (TS1) with masking tape.
  2. Cover four speaker terminals (TS2, TS3) with masking tape.
  3. Mask d-c power supply socket SO1.
  4. Mask socket for remote send-receive switch or relay SO2.
  5. Cover phonograph jack J1 with masking tape, and completely mask portion of phonograph jack inside of apron.
  6. Mask hole for S meter control shaft.
  7. Mask contacts on a-c power plug and hole in rear chassis apron for a-c power cord.
- (o) On bottom side of chassis mask the following coils (paper may be molded around part and held in place with masking tape):
1. Six antenna coils (T9 to T14, inclusive).
  2. Four r-f coils (T15 to T18, inclusive).
  3. Six mixer input coils (T19 to T24, inclusive).
  4. Six oscillator coils (T25 to T30, inclusive).
- (p) On bottom side of chassis mask the following capacitors with masking tape:
1. Seven variable mica compression capacitors (C7 to C12, inclusive, and C55).
  2. Three variable ceramic capacitors (C29, C30, and C31).
  3. Eight variable ceramic capacitors (C88 to C91, inclusive, and C94 to C97, inclusive).
  4. Four variable mica compression capacitors (C92, C93, C98, and C99).
  5. Four variable air capacitors (C100 to C103, inclusive).
- (q) Completely mask antenna trimmer capacitor on bottom of chassis. Paper should be molded around this part and held in place with masking tape.
- (r) Completely mask crystal phasing capacitor and BFO pitch control capacitor on back of front panel.
- (s) With masking tape, cover completely all switch wafers on under side of chassis.

(*t*) With masking tape, mask all points where shafts pass through panels or stage shields.

(*u*) Mask each of 12 tapped holes around bottom edge of chassis.

(4) DRYING. Place the equipment in a drying oven or under infra-red lamps, and bake for 6 hours at 140°F.

**CAUTION:** Do not exceed 140°F. If wax should begin to melt in any of the components, decrease the temperature and increase the drying time 1 hour for each decrease of 10°F.

(5) VARNISHING.

(*a*) Inspect all masking to make sure it has not loosened during the drying process.

(*b*) Apply three coats of moistureproofing and fungiproofing varnish (Lacquer, Fungus-resistant, Spec No. 71-2202 (Stock No. 6G1005.3), or equal). Allow a 15- to 20-minute drying period after each coat.

(*c*) Using a brush, apply the varnish to those components not reached by the spray. Take special care that all wiring is adequately covered by varnish.

(*d*) When varnish is completely dry, remove all masking. Where there is more than 1 inch of unvarnished wire, apply one coat of varnish with a brush.

(6) REASSEMBLY.

**NOTE:** Do not reassemble equipment until varnish is thoroughly dry.

(*a*) Reassemble units by following instructions for disassembly in reverse order.

(*b*) Check each unit for over-all operation. Particularly check mechanical operations of tuning and switching.

(*c*) Align the receiver if necessary.

(7) MARKING. Mark the equipment with "MFP" and the date of treatment. Example: MFP-8 June 1944.

## SECTION V SUPPLEMENTARY DATA

### 32. MAINTENANCE PARTS LIST FOR RADIO RECEIVER AN/GRR-2.

Ref symbol	Signal Corps stock No.	Name of part and description	Quan per unit	Mfrs part and code No.	†Station stock	†Region stock
	2C4535.3	RADIO RECEIVER: phone and c-w; freq range 0.55 to 43 mc; 6 bands; 110-125-v; 50/60 cps.		SX-28 (H1)		
C1, 1.1, 1.2, 2, 2.1, 2.2, 2.3	3D9187VE5	CAPACITOR: variable; 4-gang; 7-section; 3-section @ 250 mmf; 4-section @ 187.5 mmf.	1	**48B050 (R1)		
C3, 3.1, 3.2, 3.3, 4, 4.1, 4.2, 4.3, 5, 5.1, 5.2, 5.3	3D9187VE5.1	CAPACITOR: variable; 4-gang; 12-section; 4-section @ 16 mmf; 4-section @ 23 mmf; 4-section @ 28 mmf.	1	**485051 (R1)		
C6	3D9050V-63	CAPACITOR: variable; 5-50-mmf; 5,000 v dc (test).	1	**48A053 (R1)		
C7	3DA2.577V	CAPACITOR: variable; mica compression; 2,160-mmf; 510-v (nominal).	1	1846 (U8)		*
C8	3DA3.110V	CAPACITOR: variable; mica compression; 2,962-mmf; 510-v (nominal).	1	1842 (U8)		*
C9	3DA2.368V	CAPACITOR: variable; mica compression; 2,276-mmf; 510-v (nominal).	1	1841 (U8)		*
C10	3DA2	CAPACITOR: variable; mica compression; 1,600-mmf; 510-v (nominal).	1	1845 (U8)		*
C11	3D9920V	CAPACITOR: variable; mica compression; 876-mmf; 510-v (nominal).	1	1844 (U8)		*
C12	3D9566V	CAPACITOR: variable; mica compression; 515-mmf; 510-v (nominal).	1	1843 (U8)		*

C13	3D9005-27	CAPACITOR: mica; 5-mmf; 350 v dc (working); osc stabilization; temperature-compensating.	1	S-2739 (U8)		*
C14, 15, 18, 19, 22, 33, 27, 23, 35, 39, 42, 50, 57, 62, 65	3DA20-5.1	CAPACITOR: paper; 0.02-mf; 400 v dc (working).	15	**46AW203J (S8)	*	*
C16, 20, 24, 28, 36, 56, 67	3DA20-13.2	CAPACITOR: paper; 0.02-mf; 200 v dc (working).	7	**46AY203J (S8)	*	*
C17, 21, 26, 33, 53, 58, 59, 63, 66, 67	3DA50-67.1	CAPACITOR: paper; 0.05-mf; 200 v dc (working).	10	AB (S8)	*	*
C25, 70, 76	3DA2-29	CAPACITOR: mica; 0.002-mf; 500 v dc (working).	3	1467 (A1) or (C15)	*	*
C29	3D9006V-9	CAPACITOR: variable; 2-6-mmf; ceramic.	1	820A (C4)		*
C30, 31	3D9020V-21	CAPACITOR: variable; 4-20-mmf; ceramic.	2	820B (C4)		*
C32	3D9025V-37	CAPACITOR: air; variable; 5-25-mmf.	1	**48A039 (R1)		
C37, 60, 68, 69	3D287	CAPACITOR: mica; 50-mmf; 500 v dc (working).	4	1468 (A1)	*	*
C38, 79, 80, 83	3D9006-6	CAPACITOR: 5-6-1/2 mmf; fixed ceramic; 500 v dc (working).	4	Class D (C4)	*	*
C40, 86	3K2051122	CAPACITOR: mica; 0.005-mf; 500 v dc (working); low-loss.	2	1468L (A1)		*
C41, 44		CAPACITOR: electrolytic; 2 sec; 40 mf @ 25 v dc (working) and 10 mf @ 300 v dc (working).	1	EL (S8)	*	*
C43	3DA5-6	CAPACITOR: mica; 0.005-mf; 300 v dc (working).	1	1467 (A1)		*
C45, 46, 54	3DA50-1.3	CAPACITOR: paper; 0.05-mf; 400 v dc (working).	3	AB (S8)	*	*
C49	3DB30-14	CAPACITOR: electrolytic; 30-mf; 450 v dc (working)	1	D8290 (S8)	*	*
C51, 52, 74	3DA10-146.1	CAPACITOR: paper; 0.01-mf; 600 v dc (working).	3	AB (S8)	*	*

† Parts not stocked in station or region stock are carried in depot stock.

\* Indicates stock available.

\*\* Refers to Hallicrafters part numbers.

## 32. MAINTENANCE PARTS LIST FOR RADIO RECEIVER AN/GRR-2 (contd.).

Ref symbol	Signal Corps stock No.	Name of part and description	Quan per unit	Mfrs part and code No.	†Station stock	†Region stock
C47, 48	3DB40-26	CAPACITOR: electrolytic; dual; 40 mf @ 25 v dc (working) and 30 mf @ 450 v dc (working).	1	2583 (S8)	*	*
C61	3D9250-3	CAPACITOR: mica; 0.00025-mf; 500 v dc (working).	1	1468 (A1)		*
C64, 71	3D9100-8	CAPACITOR: mica; 0.0001-mf; 500 v dc (working).	2	1468 (A1)		*
C78, 82	3D9010-34	CAPACITOR: 10-mmF; 500 v dc (working); ceramic.	2	Class D (C4)		*
C87	3DB25-26	CAPACITOR: paper; 0.25-mf; 200 v dc (working).	1	**46AT254J (S8)		*
C88, 89, 90, 91, 95, 96, 97	3D9020V-21	CAPACITOR: variable; 4-20-mmF; 1,500-v ac.	7	820-B (C4)		*
C92, 93, 98, 99	3D9025V-43	CAPACITOR: variable; mica; compression; 3-25-mmF.	4	1788 (U8)		*
C94	3D9006V-8	CAPACITOR: variable; 2-6-mmF.	1	820A (C4)		*
C100, 101, 102	3D9023V-2	CAPACITOR: variable; 5-25-mmF.	3	5-24 (S3)		
C103	3D9012V-3	CAPACITOR: variable; 1-10-mmF.	1	22-5230 (M11)		
CH1	3C347-10	CHOKER: filter; 13 h @ 100 ma; 300-ohm d-c resistance.	1	1D25 (G19)		*
CH2	3C344-7	CHOKER: filter; 4 h; 220-ohm d-c resistance.	1	10C5 (S27)		*
CH3	3C4010-2	FILTER: i-f, 455-ke wave-trap assem; (contains C55).	1	53A012 (S26)		*
FS1	3Z2601.5	FUSE: 1-1/2-amp; 250-v; type 3AG.	1	1041 (L3)	*	*
J1	2Z5572-4	JACK: phonograph; standard tip and sleeve.	1	503C (U4)		*
J2	4C4311-4	JACK: headphone; standard tip and sleeve.	1	ST687 (U4)		*
LM1, 2	2Z5927	LAMP: pilot; 6.3-v; 0.25-amp.	2	44 (G3)	*	*
LM3	2Z5952	LAMP: pilot; 6.3-v; 0.15-amp.	1	47 (G3)	*	*
M1	3F895-13	METER: carrier level; 5-ma movement.	1	**82A007 (H1)		*
PL2	2C4535.1 C5	PLUG: 2-conductor; with a-c power cord.	1	**87A078 (E9)		*
R1, 7, 11, 15, 19, 24, 36, 37, 48, 57, 59, 69	3Z6700-25	RESISTOR: 100,000-ohm; 1/2-w; carbon.	12	504 (E3)	*	*

R2	2Z7269-41	RESISTOR: pot; 10,000-ohm; curve No. 8 reversed.	1	**25A066 (C28)	*	*
R3, 8, 14	3Z6030-41	RESISTOR: 300-ohm; 1/2-w; carbon.	3	504 (E3)	*	*
R4	3Z6625-8	RESISTOR: 25,000-ohm; 1/2-w; carbon.	1	504 (E3)	*	*
R5, 9, 13, 17, 22, 34, 56	3RC20AE102K	RESISTOR: 1,000-ohm; 1/2-w; carbon.	7	504 (E3)	*	*
R6	3Z6568-12	RESISTOR: 6,800-ohm; 2-w; carbon.	1	BT-2 (I2)	*	*
R10, 18, 23, 63	3Z6300-32	RESISTOR: 3,000-ohm; 1/2-w; carbon.	4	504 (E3)	*	*
R12	3Z6040-27	RESISTOR: 400-ohm; 1/2-w; carbon.	1	504 (E3)	*	*
R16	3Z6027-11	RESISTOR: 270-ohm; 1/2-w; carbon.	1	504 (E3)	*	*
R20, 25, 27, 55, 61, 64	3Z6750-4	RESISTOR: 500,000-ohm; 1/2-w; carbon.	6	504 (E3)	*	*
R21	3Z6025-21	RESISTOR: 250-ohm; 1/2-w; carbon.	1	504 (E3)	*	*
R26	3RC21AE182K	RESISTOR: 1,800-ohm; 1/2-w; carbon.	1	504 (E3)	*	*
R28	3Z6010-39	RESISTOR: 100-ohm; 1/2-w; carbon.	1	504 (E3)	*	*
R29	2Z7267.9	RESISTOR: pot; 500-ohm; curve No. 7 reversed.	1	**25A022 (C28)	*	*
R30	3Z6627-11	RESISTOR: 27,000-ohm; 2-w; carbon.	1	BT-2 (I2)	*	*
R31, 32	3Z6615-103	RESISTOR: 15,000-ohm; tapped at 11,000 and 4,000 ohms; 11,000-ohm section 2 w; 4,000-ohm section 7 w.	1	CANDOHM (M12)	*	*
R33	2Z7272-50	RESISTOR: pot; 500,000-ohm.	1	**25A065 (C28)	*	*
R35	2Z7272-51	RESISTOR: pot; 500,000-ohm; with SPST switch.	1	**25A064 (C28)	*	*
R38, 46, 52, 65, 66	3Z6650-39	RESISTOR: 500,000-ohm; 1/2-w; carbon.	5	504 (E3)	*	*
R39	3Z6720-1	RESISTOR: 200,000-ohm; 1/2-w; carbon.	1	504 (E3)		*
R40, 41, 60	3Z6725-9	RESISTOR: 250,000-ohm; 1/2-w; carbon.	3	504 (E3)	*	*
R42	3Z6022-6	RESISTOR: 220-ohm; 2-w; wire-wound.	1	BW-2 (I2)	*	*
R43, 45	3Z6620-22	RESISTOR: 20,000-ohm; 2-w; carbon.	2	316 (C11)	*	*
R44	3Z6500-106	RESISTOR: 5,000-ohm; 10-w; wire-wound.	1	CC (U4)	*	*
R47	3Z5998-5	RESISTOR: 8-ohm; 1/2-w; carbon.	1	504 (E3)	*	*

† Parts not stocked in station or region stock are carried in depot stock.

\* Indicates stock available.

\*\* Refers to Hallicrafters part numbers.

## 32. MAINTENANCE PARTS LIST FOR RADIO RECEIVER AN/GRR-2 (contd.).

Ref symbol	Signal Corps stock No.	Name of part and description	Quan per unit	Mfrs part and code No.	†Station stock	†Region stock
R49, 70	3Z6801-39	RESISTOR: 0.1-meg; 1/2-w; carbon.	2	710 (C4)	*	*
R50, 67, 72	3Z6050-8	RESISTOR: 500-ohm; 1/2-w; carbon.	3	504 (E3)	*	*
R51	3RC31BE203J	RESISTOR: 20,000-ohm; 1-w; carbon.	1	314 (C4)	*	*
R53	2Z7270.34	RESISTOR: pot; 50,000-ohm; with DPST switch.	1	*25A067 (C28)	*	*
R54	3Z6003E5-1	RESISTOR: 35-ohm; 1/2-w; carbon.	1	310 (C4)	*	*
R58	3Z6020-7	RESISTOR: 200-ohm; 1/2-w; carbon.	1	504 (E3)	*	*
R68	3Z6120-14	RESISTOR: 1,200-ohm; 1/2-w; carbon.	1	504 (E3)	*	*
R71	3Z6500-119	RESISTOR: 5,000-ohm; 1-w; carbon.	1	314 (C4)	*	*
SO1	2Z8678.74	SOCKET: 8-prong; octal.	1	MIP-8T (A13)		
V1-14 Incl.	2Z8659-6	SOCKET: 8-prong.	14	MIP-8 (A13)	*	*
V15	2Z8659-5	SOCKET: 4-prong.	1	MIP-4 (A13)		*
SW1, 2, 6, 7	3Z9825-62.46	SWITCH: rotary; wafer; 4-section; 3 position	4	19489-CH (O1)		*
SW4	3Z9846.3	SWITCH: toggle; SPDT.	1	21350 (H12)		*
SW8-1 to 8-15 Incl.	3Z3345-1.1	SWITCH: band change assem 10 sections; 6 position	1	61B009 (H12)		*
SW9-1, 9-2, 9-3	3Z9825-62.43	SWITCH: rotary; 3-section; 6 position; selectivity control.	3	22659-H3 (O1)		*
SW10	3Z9858-8.48	SWITCH: toggle; SPDT.	1	20994KF (H12)		*
T1	2Z9641.49	TRANSFORMER: 1st i-f assem, 455 kc.	1	**50B082B (S3)		
T2	2Z9641.69	TRANSFORMER: 2d i-f and crystal network assem, 455 kc.	1	**50B081 (S3)		
T3	2Z9641.102	TRANSFORMER: diode i-f assem; 455 kc.	1	**50B083 (S26)		
T4	2Z9641.48	TRANSFORMER: BFO assem; 455 kc.	1	716 (S26)		
T5	2Z9641.55	TRANSFORMER: ANL amplr assem; 455 kc.	1	**50B097F (S26)		
T6	2Z9641.47	TRANSFORMER: AVC amplr assem; 455 kc.	1	717 (S26)		

T7	2Z9613.98	TRANSFORMER: power; primary 117 v; 50/60 cps; second No. 1: 580 v ct @ 185 ma; No. 2: 6.3 v @ 5.5 amp; No. 3: 5 v @ 3 amp.	1	9G62 (G19)		
T8	2C4535.1/T5	TRANSFORMER: output; primary 10,000-ohm ct; second 100-500-5,000-ohm.	1	*55A009 (G19)		
T9	2C4535/T3	TRANSFORMER: ant.; 3-5.8-mc; air core.	1	696 (S26)		
T10	2C4535/T9	TRANSFORMER: ant.; 5.8-11.5-mc; air core.	1	697 (S26)		
T11	2C4535/T21	TRANSFORMER: ant.; 10.5-21-mc; air core.	1	51A278 (S26)		
T12	2C4535/T1	TRANSFORMER: ant.; 21-43-mc; air core.	1	699 (S26)		
T13	2C4535/T10	TRANSFORMER: ant.; 550-1, 600-ke; air core.	1	694 (S26)		
T14	2C4535/T11	TRANSFORMER: ant.; 1.6-3 mc.; air core.	1	695 (S26)		
T15	2C4535/T8	TRANSFORMER: r-f; 3-5.8-mc; iron core.	1	700 (S26)		
T16	2C4535/T4	TRANSFORMER: r-f; 5.8-11.5-mc; iron core.	1	701 (S26)		
T17	2C4535/T5	TRANSFORMER: r-f; 10.5 to 21-mc; iron core.	1	702 (S26)		
T18	2C4535/T6	TRANSFORMER: r-f; 21-42-mc; iron core.	1	703 (S26)		
T19	2C4535/T20	TRANSFORMER: mixer input; 550-1, 600-ke; air core.	1	704 (S26)		
T20	2C4535/T12	TRANSFORMER: mixer input; 1.6-3-mc; air core.	1	705 (S26)		
T21	2C4535/T18	TRANSFORMER: mixer input; 3-5.8-mc; iron core.	1	706 (S26)		
T22	2C4535/T13	TRANSFORMER: mixer input; 5.8-11.5-mc; iron core.	1	707 (S26)		
T23	2C4535/T14	TRANSFORMER: mixer input; 10.5-21-mc; iron core.	1	708 (S26)		
T24	2C4535/T15	TRANSFORMER: mixer input; 21-42-mc; iron core.	1	709 (S26)		
T25	2C4535/T16	TRANSFORMER: h-f osc; 550-1600-ke; iron core.	1	710 (S26)		
T26	2C4535/T7	TRANSFORMER: h-f osc; 1.6-3-mc; iron core.	1	711 (S26)		
T27	2C4535/T17	TRANSFORMER: h-f osc; 3-5.8-mc; iron core.	1	712 (S26)		
T28	2C4535/T2	TRANSFORMER: h-f osc; 5.8-11.5-mc; iron core.	1	713 (S26)		
T29	2C4535/T22	TRANSFORMER: h-f osc; 10.5-21-mc; iron core.	1	714 (S26)		
T30	2C4535/T19	TRANSFORMER: h-f osc; 21-42-mc; iron core.	1	715 (S26)		
VI, 9	2T176	TUBE: VT-176.	2	6AB7 (R2)	*	*

† Parts not stocked in station or region stock are carried in depot stock.

\* Indicates stock available.

\*\* Refers to Hallicrafters part numbers.

60 32. MAINTENANCE PARTS LIST FOR RADIO RECEIVER AN/GRR-2 (contd.).

Ref symbol	Signal Corps stock No.	Name of part and description	Quan per unit	Mfrs part and code No.	†Station stock	†Region stock
V2, 6	2T117	TUBE: VT-117.	2	6SK7 (R2)	*	*
V3, 4	2V6SA7	TUBE: VT-150.	2	6SA7 (R2)	*	*
V5	2T87	TUBE: VT-87.	1	6L7 (R2)	*	*
V7, 8	2T93	TUBE: VT-93.	2	6B8 (R2)	*	*
V10	2T90	TUBE: VT-90.	1	6H6 (R2)	*	*
V11	2T94	TUBE: VT-94.	1	6J5 (R2)	*	*
V12	2T105	TUBE: VT-105.	1	6SC7 (R2)	*	*
V13, 14	2T107A	TUBE: VT-107-A.	2	6V6GT (R2)	*	*
V15	2T145	TUBE: VT-145.	1	5Z3 (R2)	*	*

† Parts not stocked in station or region stock are carried in depot stock.

\* Indicates stock available.

\*\* Refers to Hallicrafters part numbers.

### 33. LIST OF MANUFACTURERS.

<b>Code</b>	<b>Manufacturer's Name</b>
A1	Aerovox Corp.
A13	American Phenolic Corp.
C4	Centralab
C11	Climax Engineering Co.
C15	Cornell-Dubilier Electric Corp.
C28	Chicago Telephone Supply Co.
E3	Erie Resistor Corp.
E9	Essex Wire Corp.
G3	General Electric Co.
G19	General Transformer Corp.
H1	Hallicrafter, The, Co.
H12	Hart and Hegeman Co.
I2	International Resistance Co.
L3	Littelfuse Lab.
M11	Meissner Mfg. Co.
M12	Muter Co.
O1	Oak Mfg. Co.
R1	Radio Condenser Co.
R2	RCA Mfg. Co.
S3	Sickles, F. W. Co.
S8	Sprague Products Co.
S26	S. W. Inductor Co.
S27	Standard Transformer Co.
U4	Utah Radio Products Co.
U8	Underwood Electric Co.

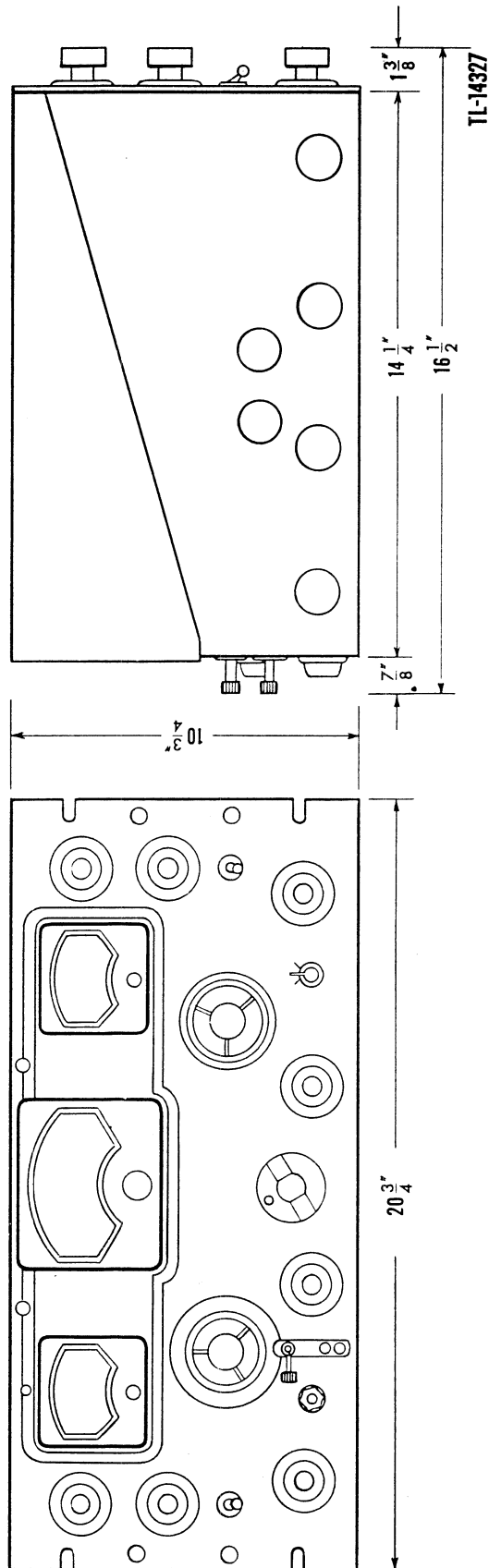
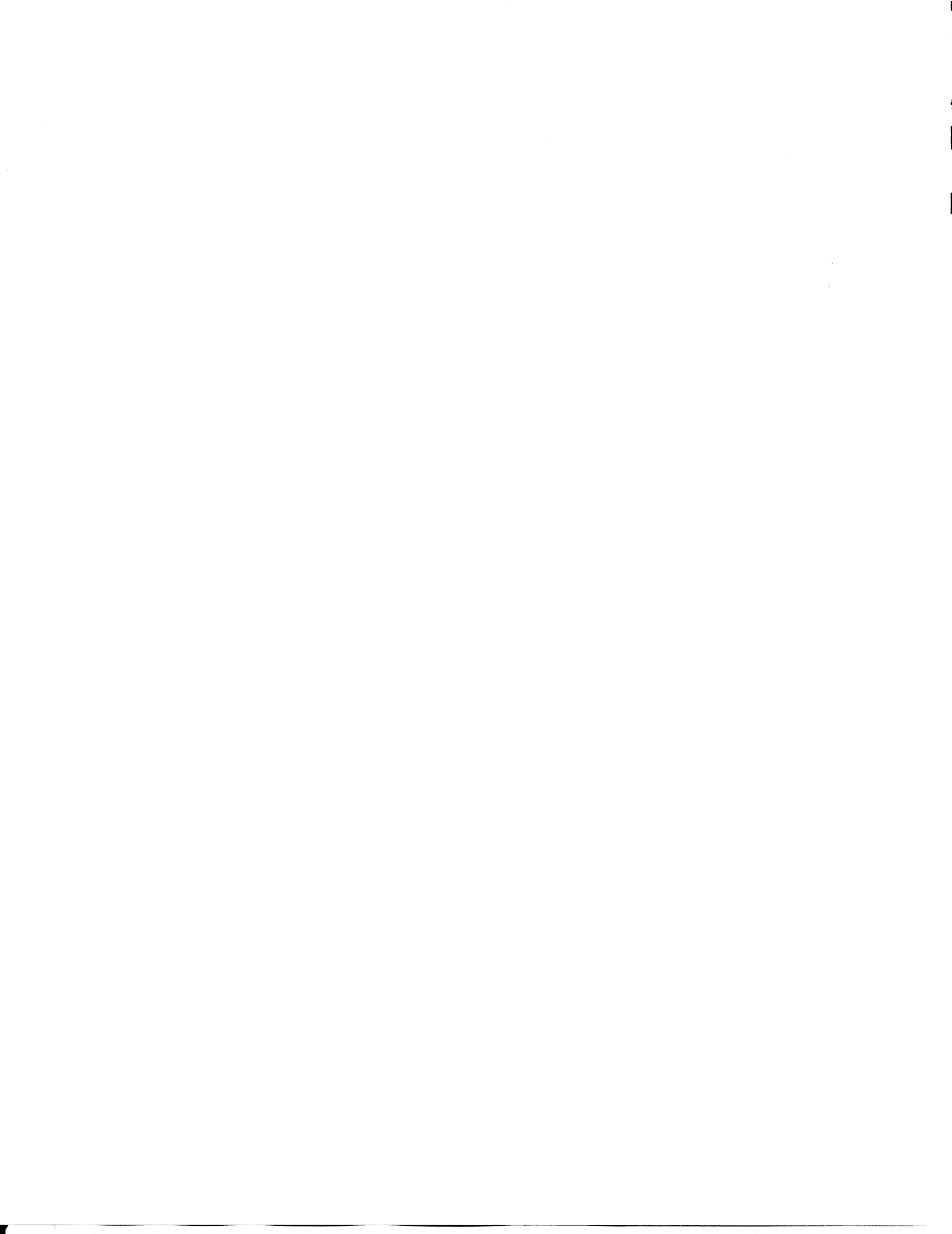

Figure 26. Dimensional drawing.





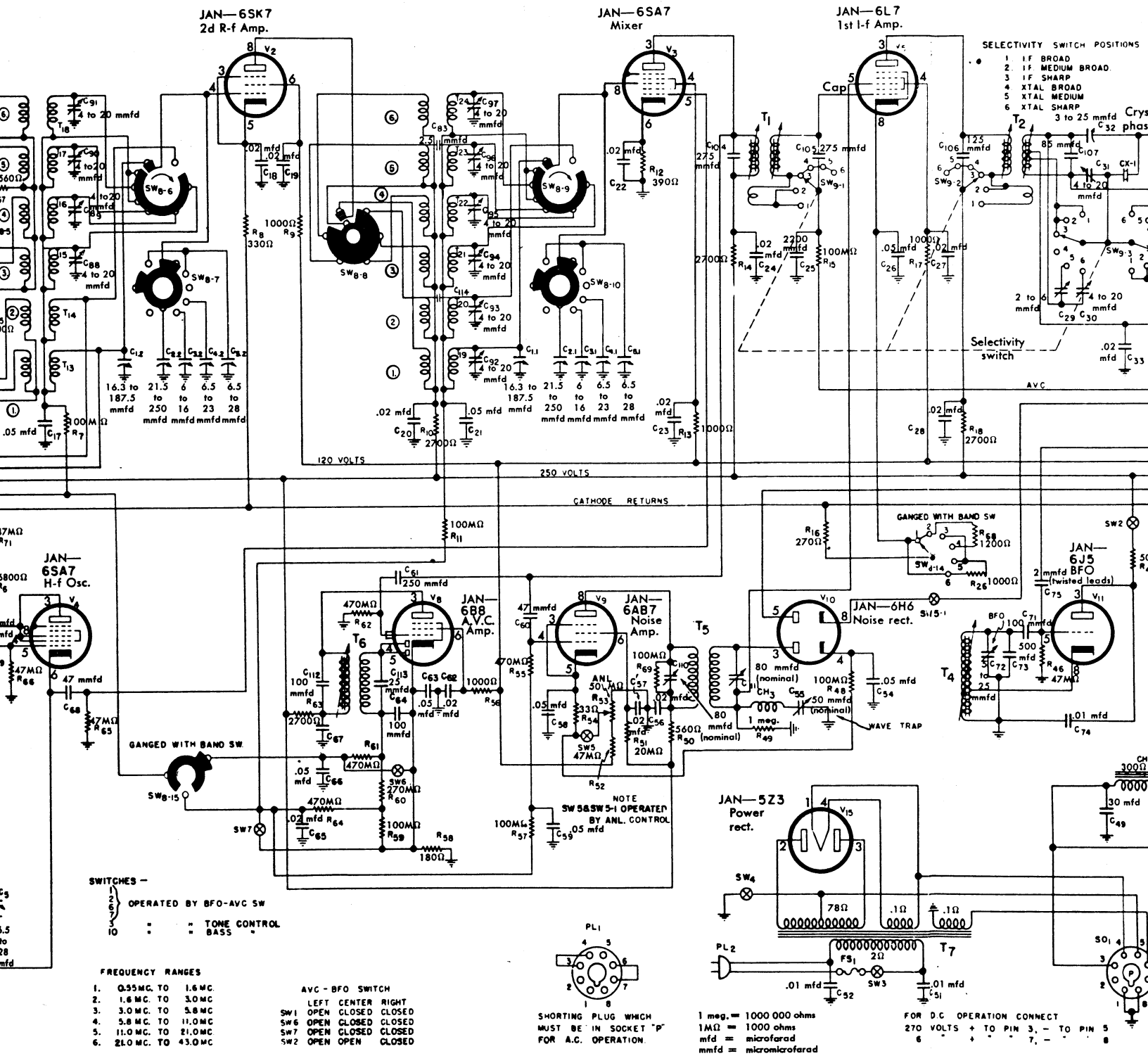
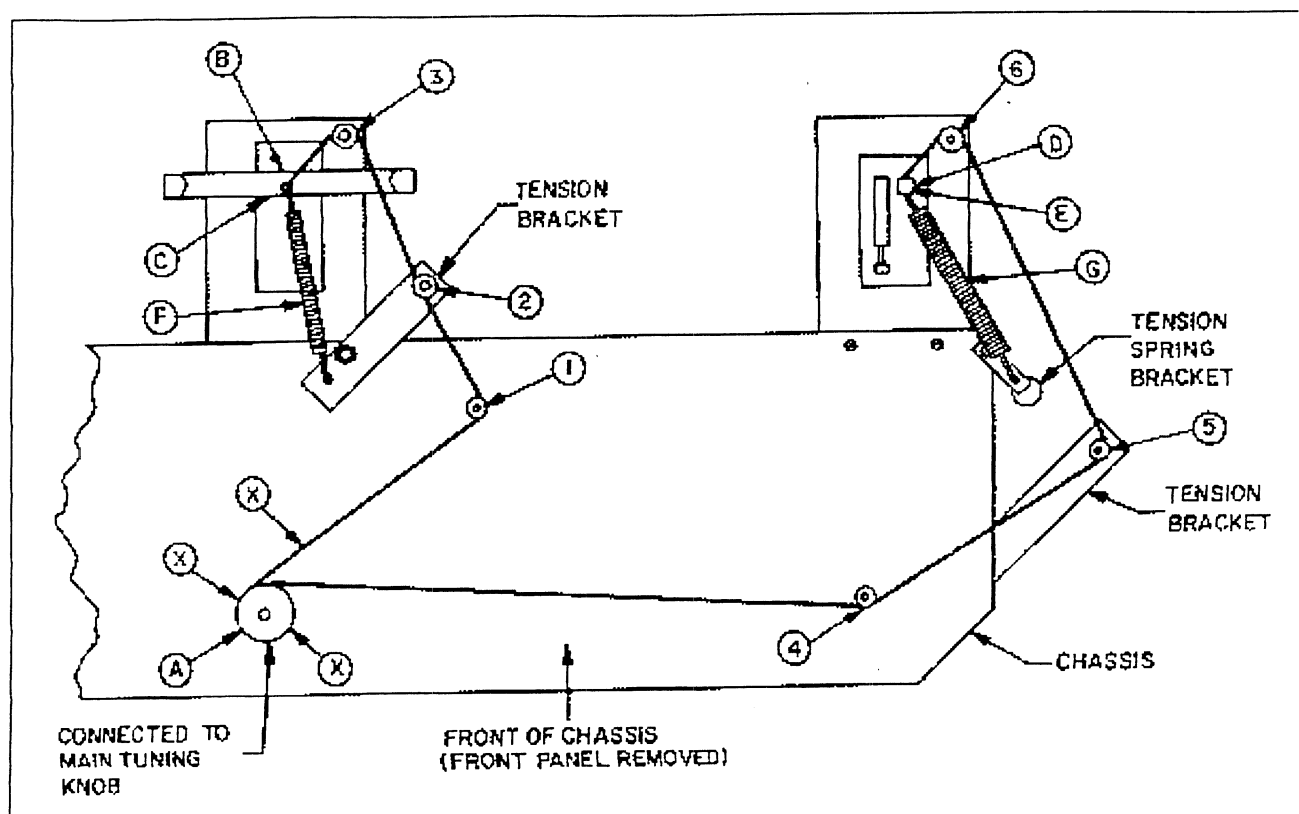

Figure 27. Radio Receiver AN/GRR-2, schematic diagram.





1. Make sure both metal indicator arrows are in the down position and there is no tension on the springs (F) and (G).
2. Set the receiver on end with bottom of chassis facing the operator.
3. Set the band switch to position 1.6-3.0 MC. (Machine screw on band switch shaft bushing is now facing operator.)
4. Cut the dial cord at least 26 inches long.
5. Make a slip knot 10 inches from one end of cord; place over machine screw (A), and draw tight.
6. Set band switch to position .55-1.6 MC.
7. Wind short end of cord once around bushing (X), then position cord over pulley (1), under pulley (2), and over pulley (3).
8. Open slot (B) with pliers; run cord through brass blocking washer, tie a double knot, and insert through slot (C). (Do not allow any slack in cord.)
9. Close (B) with pliers.
10. Position the longer length of cord under pulley (4) and over pulley (5) and pulley (6) respectively.
11. Insert and pull cord through brass sleeve (D) and blocking washer, and tie cord to end loop (E) of tension spring (G), allowing only a slight tension on spring. Make sure there is no slack in this length of cord.
12. Turn band switch to each of the six positions, noting the position of the metal indicator arrows.
13. Tension and position of the knots with respect to the brass blocking washers are critical, making careful stringing of the cord necessary. Adjust the tension brackets if necessary. (Cord may break if not correct.)





